

# Ansys 2025/R2

POWERING INNOVATION THAT DRIVES HUMAN ADVANCEMENT

© 2025 ANSYS, Inc. or its affiliated companies  
Unauthorized use, distribution, or duplication is prohibited.

## Getting Started with Icepak®



ANSYS, Inc.  
Southpointe  
2600 Ansys Drive  
Canonsburg, PA 15317  
[ansysinfo@ansys.com](mailto:ansysinfo@ansys.com)  
<https://www.ansys.com>  
(T) 724-746-3304  
(F) 724-514-9494

Release 2025 R2  
July 2025

ANSYS, Inc. and  
ANSYS Europe,  
Ltd. are UL  
registered ISO  
9001:2015 com-  
panies.

## **Copyright and Trademark Information**

© 1986-2025 ANSYS, Inc. Unauthorized use, distribution or duplication is prohibited.

ANSYS, Ansys Workbench, AUTODYN, CFX, FLUENT and any and all ANSYS, Inc. brand, product, service and feature names, logos and slogans are registered trademarks or trademarks of ANSYS, Inc. or its subsidiaries located in the United States or other countries. Icem CFD is a trademark used by ANSYS, Inc. under license. All other brand, product, service and feature names or trademarks are the property of their respective owners. FLEXIm and FLEXnet are trademarks of Flexera Software LLC.

## **Disclaimer Notice**

THIS ANSYS SOFTWARE PRODUCT AND PROGRAM DOCUMENTATION INCLUDE TRADE SECRETS AND ARE CONFIDENTIAL AND PROPRIETARY PRODUCTS OF ANSYS, INC., ITS SUBSIDIARIES, OR LICENSORS. The software products and documentation are furnished by ANSYS, Inc., its subsidiaries, or affiliates under a software license agreement that contains provisions concerning non-disclosure, copying, length and nature of use, compliance with exporting laws, warranties, disclaimers, limitations of liability, and remedies, and other provisions. The software products and documentation may be used, disclosed, transferred, or copied only in accordance with the terms and conditions of that software license agreement.

ANSYS, Inc. and ANSYS Europe, Ltd. are UL registered ISO 9001: 2015 companies.

## **U.S. Government Rights**

For U.S. Government users, except as specifically granted by the ANSYS, Inc. software license agreement, the use, duplication, or disclosure by the United States Government is subject to restrictions stated in the ANSYS, Inc. software license agreement and FAR 12.212 (for non-DOD licenses).

## **Third-Party Software**

See the legal information in the product help files for the complete Legal Notice for Ansys proprietary software and third-party software. If you are unable to access the Legal Notice, please contact ANSYS, Inc.

## Conventions Used in this Guide

Please take a moment to review how instructions and other useful information are presented in this documentation.

- Procedures are presented as numbered lists. A single bullet indicates that the procedure has only one step.
- Bold type is used for the following:
  - Keyboard entries that should be typed in their entirety exactly as shown. For example, “**copy file1**” means you must type the word **copy**, then type a space, and then type **file1**.
  - On-screen prompts and messages, names of options and text boxes, and menu commands. Menu commands are often separated by greater than signs (>). For example, “click **HFSS > Excitations > Assign > Wave Port.**”
  - Labeled keys on the computer keyboard. For example, “Press **Enter**” means to press the key labeled **Enter**.
- Italic type is used for the following:
  - Emphasis.
  - The titles of publications.
  - Keyboard entries when a name or a variable must be typed in place of the words in italics. For example, “**copy filename**” means you must type the word **copy**, then type a space, and then type the name of the file.
- The plus sign (+) is used between keyboard keys to indicate that you should press the keys at the same time. For example, “Press Shift+F1” means to press the **Shift** key and, while holding it down, press the **F1** key also. You should always depress the modifier key or keys first (for example, Shift, Ctrl, Alt, or Ctrl+Shift), continue to hold it/them down, and then press the last key in the instruction.

**Accessing Commands:** *Ribbons*, *menu bars*, and *shortcut menus* are three methods that can be used to see what commands are available in the application.

- The *Ribbon* occupies the rectangular area at the top of the application window and contains multiple tabs. Each tab has relevant commands that are organized, grouped, and labeled. An example of a typical user interaction is as follows:

"Click **Draw > Line**"



This instruction means that you should click the **Line** command on the **Draw** ribbon tab. An image of the command icon, or a partial view of the ribbon, is often included with the instruction.

- The *menu bar* (located above the ribbon) is a group of the main commands of an application arranged by category such File, Edit, View, Project, etc. An example of a typical user interaction is as follows:

"On the **File** menu, click the **Open Examples** command" means you can click the **File** menu and then click **Open Examples** to launch the dialog box.

- Another alternative is to use the *shortcut menu* that appears when you click the right-mouse button. An example of a typical user interaction is as follows:

"Right-click and select **Assign Excitation> Wave Port**" means when you click the right-mouse button with an object face selected, you can execute the excitation commands from the shortcut menu (and the corresponding sub-menus).

## Getting Help: Ansys Technical Support

For information about Ansys Technical Support, go to the Ansys corporate Support website, <http://www.ansys.com/Support>. You can also contact your Ansys account manager in order to obtain this information.

All Ansys software files are ASCII text and can be sent conveniently by e-mail. When reporting difficulties, it is extremely helpful to include very specific information about what steps were taken or what stages the simulation reached, including software files as applicable. This allows more rapid and effective debugging.

## Help Menu

To access help from the Help menu, click **Help** and select from the menu:

- **[product name] Help** - opens the contents of the help. This help includes the help for the product and its *Getting Started Guides*.
- **[product name] Scripting Help** - opens the contents of the *Scripting Guide*.
- **[product name] Getting Started Guides** - opens a topic that contains links to Getting Started Guides in the help system.

## Context-Sensitive Help

To access help from the user interface, press **F1**. The help specific to the active product (design type) opens.

You can press **F1** while the cursor is pointing at a menu command or while a particular dialog box or dialog box tab is open. In this case, the help page associated with the command or open dialog box is displayed automatically.

# Table of Contents

<b>Table of Contents</b> .....	<b>Contents-1</b>
<b>1 - Introduction</b> .....	<b>1-1</b>
<b>2 - Set Up the Project</b> .....	<b>2-1</b>
Launch the Ansys Electronics Desktop .....	2-1
Set 3D UI Options .....	2-1
Open the Project .....	2-2
Set Icepak Options .....	2-4
Set Model Units (mm) .....	2-5
Set Solution Type .....	2-6
Define Icepak Design Settings .....	2-6
<b>3 - Create and Assign Materials</b> .....	<b>9</b>
Create and Assign an Anisotropic Material .....	9
Assign Materials .....	9
Assign a Surface Material .....	10
<b>4 - Prepare and Run the Initial Simulation</b> .....	<b>4-1</b>
Assign Boundary Conditions .....	4-1
Assign the Grille, Opening, and Blocks .....	4-1
Add a Solution Setup .....	4-3
Generate a Global Mesh .....	4-4
View Global Mesh Settings .....	4-4
Generate and Examine the Mesh .....	4-4
Validate the Project .....	4-6
Create Monitors .....	4-6
Create Thermal Monitors .....	4-7
Create the CPU Monitor Point .....	4-7
Create the Memory Monitor Point .....	4-7
Create a Flow Monitor .....	4-8
Analyze the Simulation – Initial Global Mesh .....	4-8

Analyze the Model .....	4-8
Post-process the Results – Initial Global Mesh .....	4-11
Create Surface Plots .....	4-11
Create a Plane .....	4-12
Create Plots on a Plane .....	4-13
Create a Fields Summary .....	4-15
Create a Point .....	4-16
Use the Fields Calculator .....	4-17
Save the Project .....	4-19
<b>5 - Refine the Mesh and Run a Simulation .....</b>	<b>5-1</b>
Copy the Icepak Design .....	5-1
Create a Mesh Region .....	5-1
Create the Mesh Region .....	5-1
Edit Mesh Region Settings .....	5-3
Generate and Examine the Refined Mesh .....	5-4
Analyze the Simulation – Refined Mesh .....	5-6
Analyze the Model .....	5-6
Post-process the Results – Refined Mesh .....	5-9
Compare the Designs .....	5-11
Save the Project .....	5-11
<b>6 - Run Optimetric Trials .....</b>	<b>6-1</b>
Create and Assign Project Variables .....	6-1
Create Project Variables .....	6-1
Assign Project Variables .....	6-2
Add a Design of Experiments Setup .....	6-5
Analyze the Design of Experiments .....	6-10

# 1 - Introduction

This document is intended as supplementary material to Icepak for beginners and advanced users. It includes instructions to import, solve, and analyze a simple graphics card.

This chapter contains the following topic:

- Sample Project - The Graphics Card

## Sample Project - The Graphics Card

In this project, you will learn how to import the graphics card model. Icepak solves conservation equations of mass, momentum, and energy to provide flow and thermal fields.

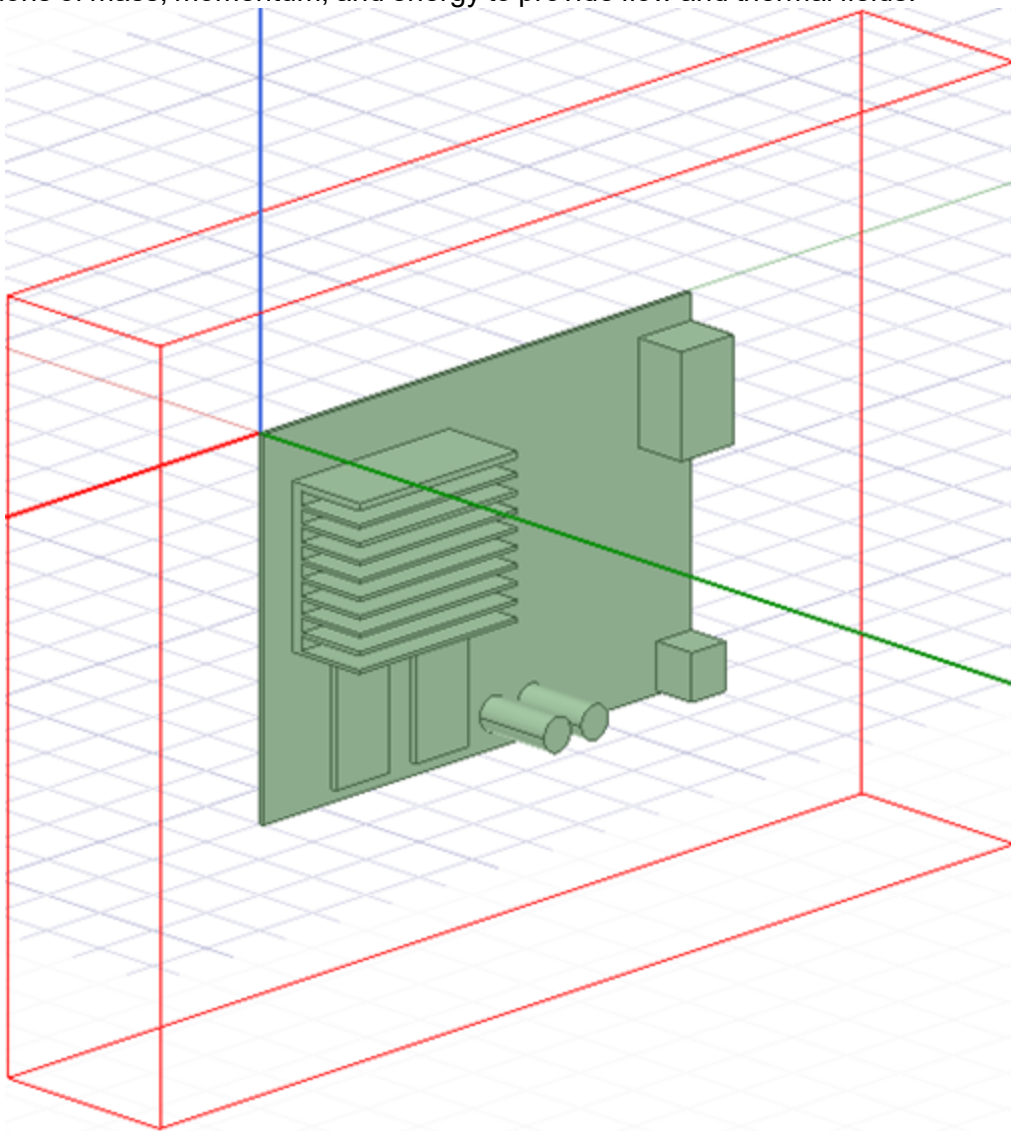

**Figure 1-1: Graphics Card**



## 2 - Set Up the Project

This chapter contains the following topics:

- Launch the Ansys Electronics Desktop
- Set Tool Options
- Set Model Units (mm)
- Set the Solution Type

### Launch the Ansys Electronics Desktop

A shortcut of the Ansys Electronics Desktop application appears on your desktop once the application is installed.

### Set 3D UI Options

Ensure that the new view orientation scheme introduced in release 2024 R1 is not being used, since the instructions and images in this guide are based on the legacy orientation scheme.

1. From the menu bar, click **View > Options**.

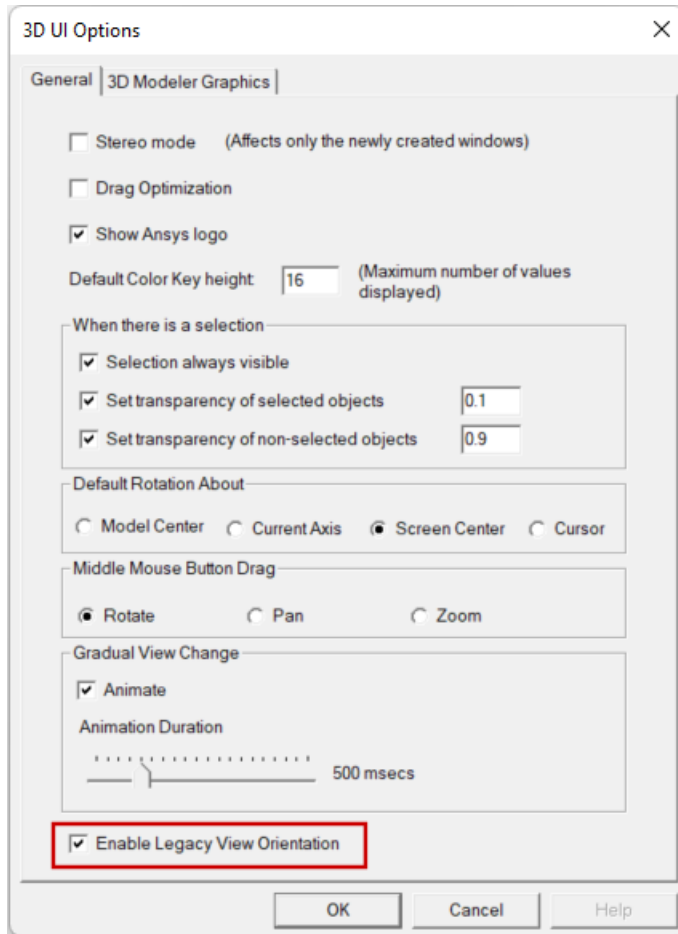

The *3D UI Options* dialog box appears.

2. Ensure that **Enable Legacy View Orientation** is enabled:



3. Click **OK**.

## Open the Project

1. On the **Desktop** ribbon tab, click  **Open Examples**. Then:
  - a. In the *Open* dialog box that appears, click the parent folder icon () once to move up one level above the *Examples* folder.
  - b. Double-click the **Help** folder and then the **Icepak** folder.
  - c. Select the file **Graphics\_Card\_Geometry.aedt** and click **Open**.
2. The model is displayed in the **3D Modeler** window.

**Note:** You can hide the grid by selecting **View > Grid Settings** and then selecting **Hide** in the **Grid Spacing** dialog box. Also, from the **View > Coordinate Systems** menu, you can hide the large coordinate triad and display a smaller coordinate triad in the bottom of the **3D Modeler** window.

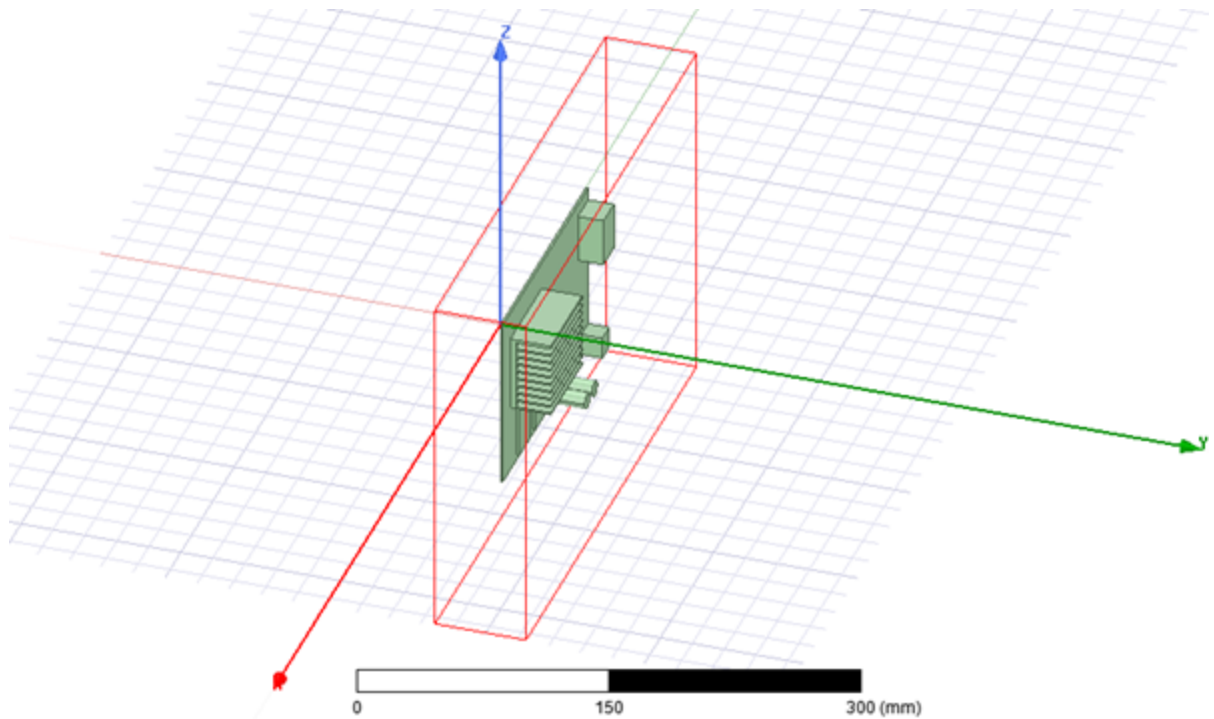

**Figure 2-1: Graphics Card model in the 3D Modeler window**

**Note:** The region (outer red bounding box), which represents the computational domain, is automatically created.

3. From the **File** menu, select **Save As**, and save the project in the desired working directory.
4. In the history tree, expand **Model > Solids > Air > Region** and select **Create Region**.
5. In the **Properties** window, note the default **X, Y**, and **Z Padding** values.

**Note:**

Ensure that you enter padding values for **-Z Padding** Data before **+Z Padding** Data.

Name	Value	Unit	Evaluated Value
Command	CreateRegion		
Coordinate...	Global		
+X Paddin...	Percentage Offset		
+X Paddin...	50		50
-X Paddin...	Percentage Offset		
-X Paddin...	50		50
+Y Paddin...	Percentage Offset		
+Y Paddin...	50		50
-Y Paddin...	Percentage Offset		
-Y Paddin...	50		50
+Z Paddin...	Percentage Offset		
+Z Paddin...	50		50
-Z Paddin...	Percentage Offset		
-Z Paddin...	50		50

Figure 2-2: Properties Window

- Expand *graphics\_card\_simple*, and review the component geometry in the history tree.

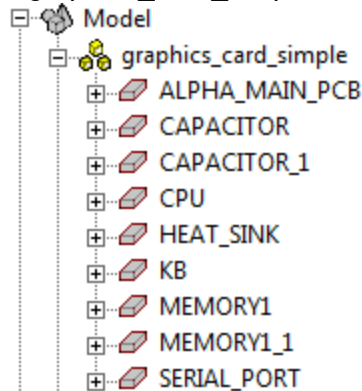

Figure 2-3: History tree

## Set Icepak Options

Verify the options under the **Tools** menu as follows:

1. Click **Tools>Options>General Options**.
2. Select **Icepak** and ensure the options are all selected as shown below.

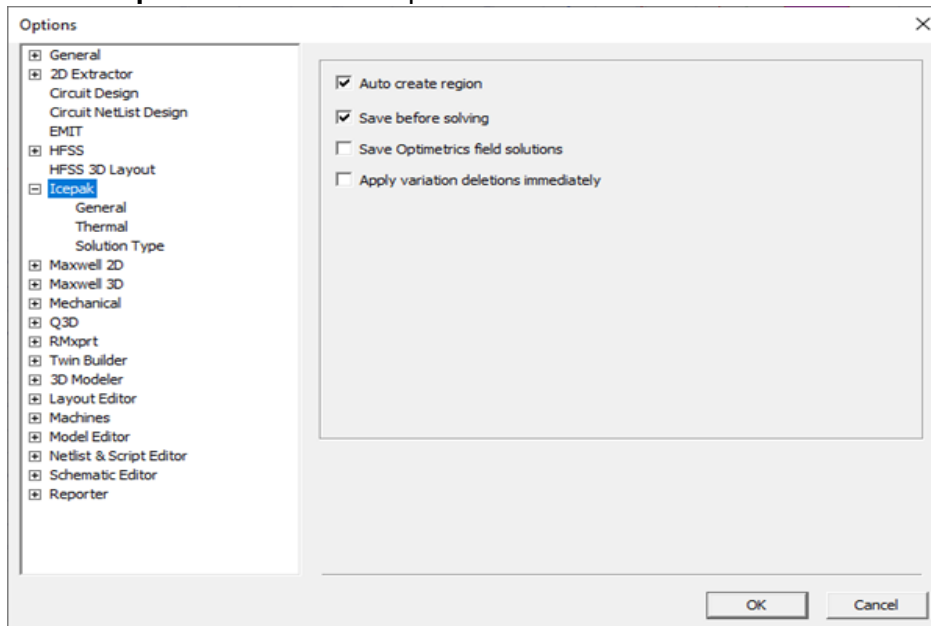

Figure 2-4: Options dialog box

3. Expand **Icepak** and click **Thermal**.
4. Ensure that the **Use Wizards for data input when creating new boundaries** is selected.

**Note:** Deselecting the **Use Wizards for data input when creating new boundaries** option provides a tabbed dialog box interface as an alternative for creating boundaries.

5. Click **OK** to close the **Options** dialog box.

## Set Model Units (mm)

Define the model units as follows:

1. From the **Modeler** menu, select **Units**.

The **Set Model Units** dialog box appears.

2. Select **mm** (millimeters) from the **Select units** drop-down list, and click **OK**.

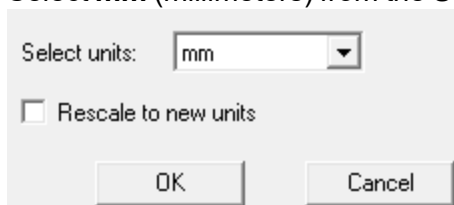

Figure 2-5: Set Model Units dialog box

## Set Solution Type

Specify the design's solution type as follows:

1. Click **Icepak>Solution Type**.

The **Solution Type** dialog box appears.

2. Ensure that **Steady State** and **Temperature and Flow** is selected and click **OK**.

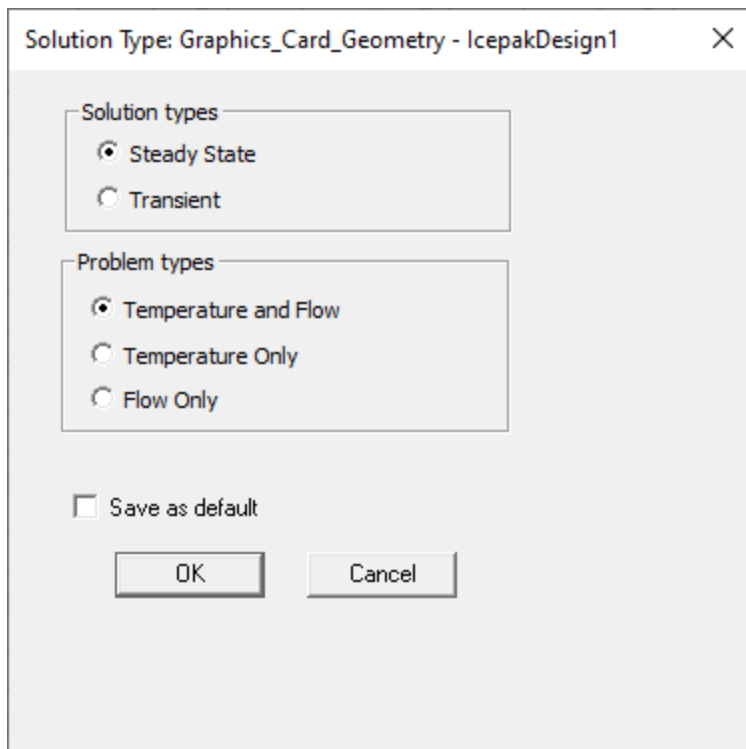

Figure 2-6: Solution Type

## Define Icepak Design Settings

Specify the project design settings as follows:

1. Click **Icepak>Design Settings**.

The **Design Settings** dialog box appears.

2. Retain the default settings on the **Ambient Conditions**, **Gravity**, **Validations**, **Export Settings**, and **Mesh** tabs and click **OK**.

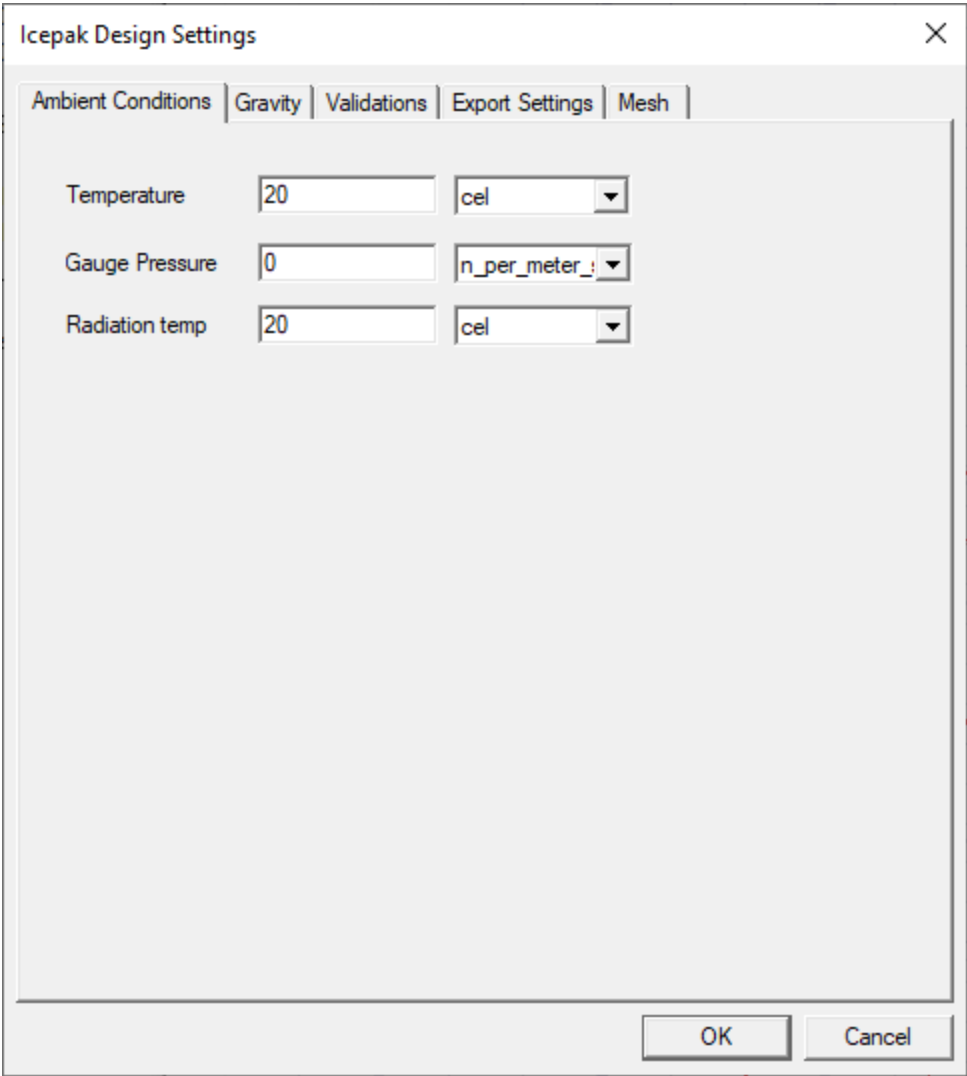

Figure 2-7: Icepak Design Settings dialog box



## 3 - Create and Assign Materials

Materials properties for the components are not defined. For this model, you will create an anisotropic material to be assigned to the PCB component and assign existing materials from the material library to other components.

### Create and Assign an Anisotropic Material

1. In the history tree, right-click on *ALPHA\_MAIN\_PCB* and select **Assign Material**.
2. In the **Select Definition** dialog box, click **Add Material**. The **View/Edit Material** dialog box appears.
3. In the **Material Name** field, enter *PCB\_Material*.
4. For **Thermal Conductivity**, click in the **Type** field and select **Anisotropic** from the drop-down list.
5. Enter the following values for the anisotropic tensors:
  - **T(1,1)**: 20
  - **T(2,2)**: 2
  - **T(3,3)**: 20
6. Enter a value of 1 for **Mass Density**, **Specific Heat**, and **Thermal Expansion Coefficient**.  
**Note:** Since we are solving a steady-state simulation, these values are just placeholders and are ignored in the solver.
7. Click **OK** to close the **View/Edit Material** dialog box.
8. Click **OK** to assign the newly created material to *ALPHA\_MAIN\_PCB* and close the **Select Definition** dialog box.

### Assign Materials

1. In the history tree, select *CPU*, *Memory1*, and *Memory1\_1* and right-click them.
2. From the right-click menu, select **Assign Material**.
3. In the **Select Definition** dialog box, select *Ceramic\_material*.
4. Click **OK** to assign the material to the selected components and close the **Select Definition** dialog box.
5. In the history tree, select *CAPACITOR*, *CAPACITOR\_1*, *Heat\_Sink*, *KB*, and *Serial\_Port* and right-click them.
6. From the right-click menu, select **Assign Material**.
7. In the **Select Definition** dialog box, verify that *AI-Extruded* is selected.
8. Click **OK** to close the **Select Definition** dialog box.

9. Select *CAPACITOR* and *CAPACITOR\_1*.
10. In the **Properties** window, ensure that the **Solve Inside** check box is deselected.

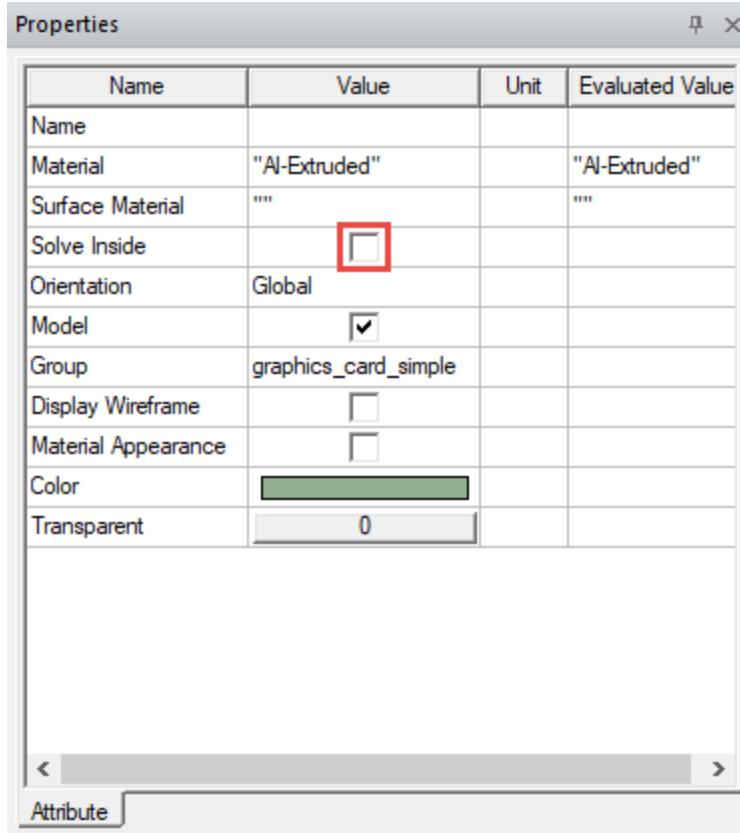

Figure 3-1: Solve Inside check box in Properties window

## Assign a Surface Material

1. In the history tree, select all of the objects. Right-click on *graphics\_card\_simple* and select **Select All**.
2. From the **Modeler** menu, select **Assign Surface Material** to open the **Select Definition** dialog box.

**Note:** You can also open the **Select Definition** dialog box from the **Properties** window by selecting **Edit** from the **Surface Material** row **Value** column drop-down list.

3. In the **Select Definition** dialog box, verify that *Steel-oxidized-surface* is selected.
4. Click **OK** to close the **Select Definition** dialog box.

# 4 - Prepare and Run the Initial Simulation

## Assign Boundary Conditions

To specify thermal properties to the objects, create boundary conditions. In this example, you'll create opening, grille, and block boundary conditions.

## Assign the Grille, Opening, and Blocks

You'll assign the opening to the minX face of the *Region* and the grille to the max X face of the *Region*.

1. Press **F** to enter face-selection mode.
2. From the **View** ribbon, select the Dimetric orientation button  from the **Orient** drop-down list.
3. Select the max X face of the *Region* object as displayed below.

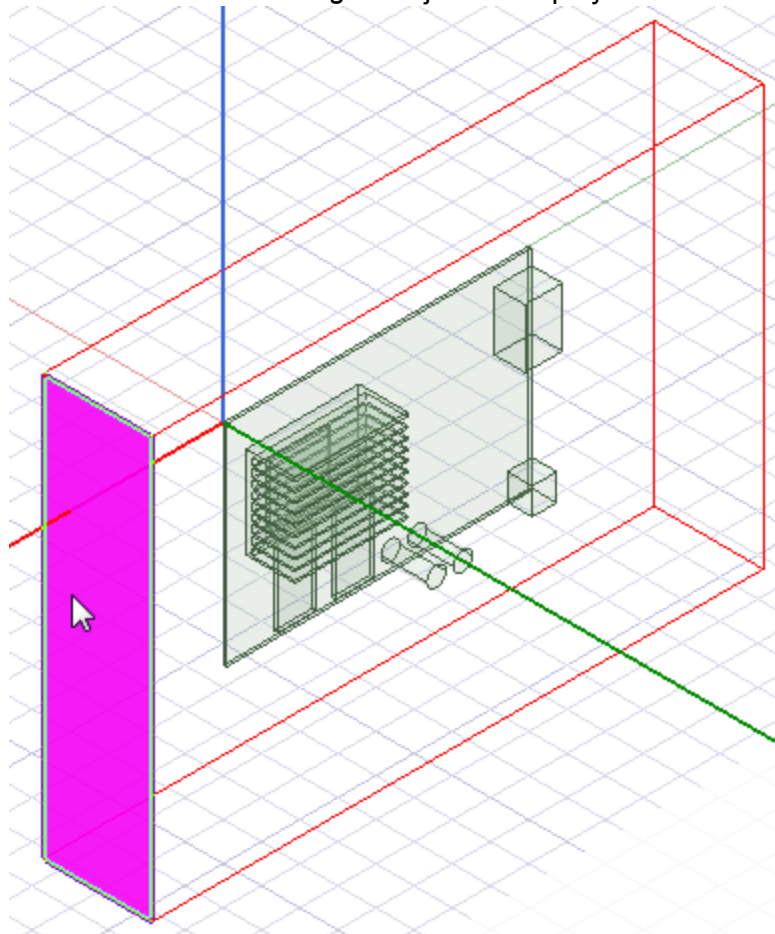

**Figure 4-1: Max X face of Region object**

4. Right-click and select **Assign Thermal>Grille**.
5. In the **Grille Thermal Model** dialog box, enter a **Free Area Ratio** of 0.8 and click **OK**. The grille boundary condition is added under **Thermal** in the **Project Manager**.
6. With the model displayed in the same orientation, hover the cursor over the min X face of the *Region* and click.

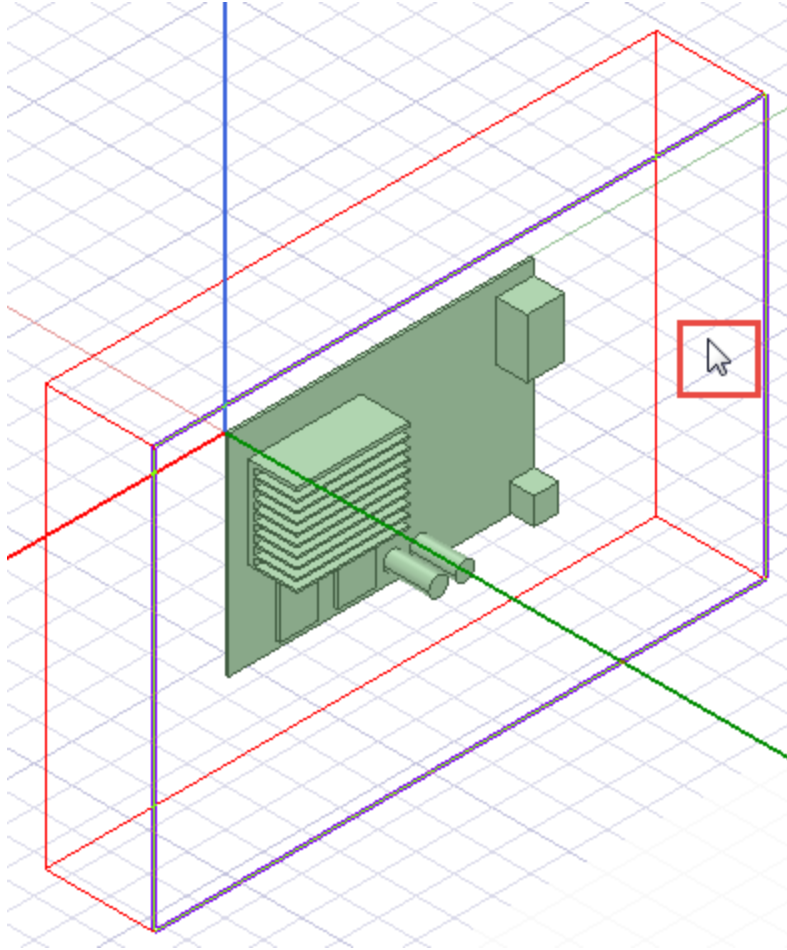

**Figure 4-2: Min X face of Region object**

7. The max Y face of the *Region* is selected. Press **B** to select the min X face, which was directly behind where your cursor was when you made the selection.

**Note:** You can also right-click and select **Next Behind** to select a face directly behind your cursor when you make a selection.

8. Right-click on the selected face and select **Assign Thermal>Opening>Free**.
9. In the **Opening Thermal Model** dialog box, select **Velocity** for **Inlet Type**, specify an **X Velocity** of 2 m\_per\_sec, click **OK**.
10. In the history tree, select *CPU*. Right-click and select **Assign Thermal>Block**.

11. In the **Block Thermal Model** dialog box, enter CPU for the **Name**, a **Total Power** of 25 **W**, and click **OK**.
12. In the history tree, select *Memory1* and *Memory1\_1*. Right-click and select **Assign Thermal>Block**.
13. In the **Block Thermal Model** dialog box, enter a **Total Power** of 5 **W** and click **OK**.
14. In the **Project Manager**, expand **Thermal** and select *Block1*.
15. In the **Properties** window, rename the boundary condition as **Memory**.

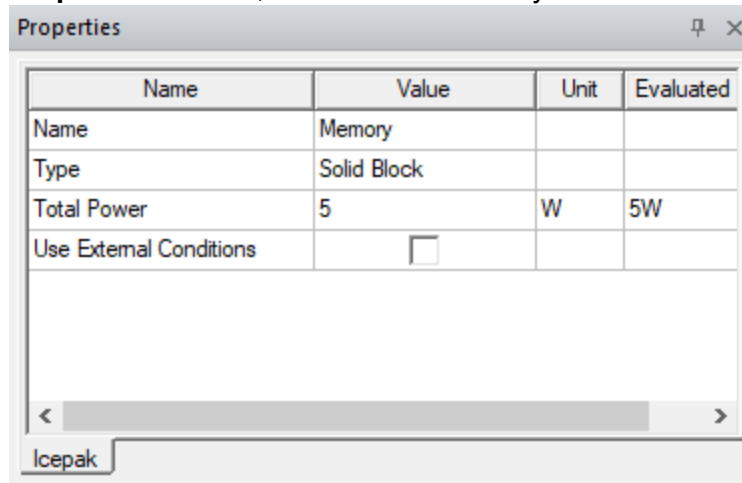

Figure 4-3: Properties window of Memory boundary condition

## Add a Solution Setup

Prior to generating a mesh, you must create a solution setup, in which you specify general and solution settings.

1. In the **Project Manager**, right-click on **Analysis** and select **Add Solution Setup**.
2. In the **Icepak Solve Setup Dialog** under **Flow Regime**, select **Turbulent** and click **Options**.
3. In the **Turbulent Flow Model** dialog box, retain the default selection of **Zero Equation** and click **OK**.
4. Retain all other default settings on the **General**, **Convergence**, and **Solver Settings** tabs.
5. Click **OK** to save the settings. The solution setup is added under **Analysis** in the **Project Manager**.
6. From the **File** menu, click **Save**.

## Generate a Global Mesh

When the model geometry is finished, you can mesh the model. In this example, you'll create an initial global mesh and proceed to solve the model before creating a copy of the Icepak design to refine the mesh around the *HEAT\_SINK* object.

## View Global Mesh Settings

1. In the **Project Manager**, right-click on **Mesh** and select **Edit Global Region**.
2. In the **Mesh Region** dialog box, examine the default mesh settings on the **General** and **Advanced** tabs.
3. Retain the default settings and click **OK**.

## Generate and Examine the Mesh

1. In the **Project Manager** under **Analysis**, right-click on the solution setup (*Setup1*) and select **Generate Mesh**. When the mesh operation is complete, the mesh loads and the **Mesh visualization** dialog box appears.
2. In the history tree, select all geometry under *graphics\_card\_simple*.
3. In the **Mesh visualization** dialog box under **Mesh display on**, select **Geometry/Boundary selection** to display the mesh for the selected objects.

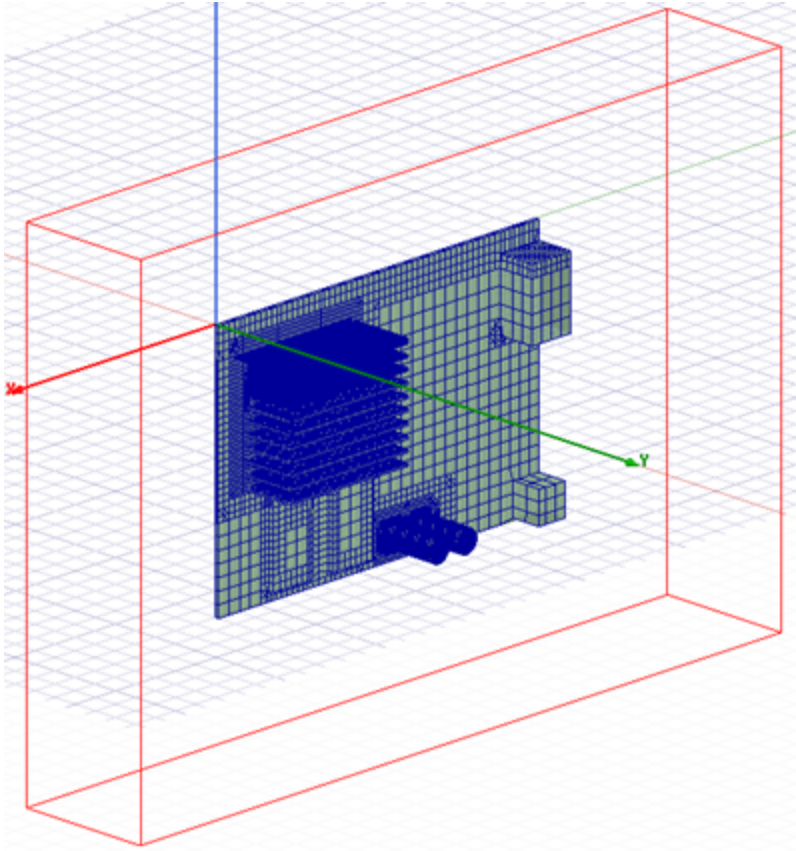

**Figure 4-4: Mesh on all objects**

4. In the history tree, select *ALPHA\_MAIN\_PCB* to display mesh only on the PCB.
5. On the **View** ribbon, click the **Right** orientation option  from the **Orient** drop-down list.

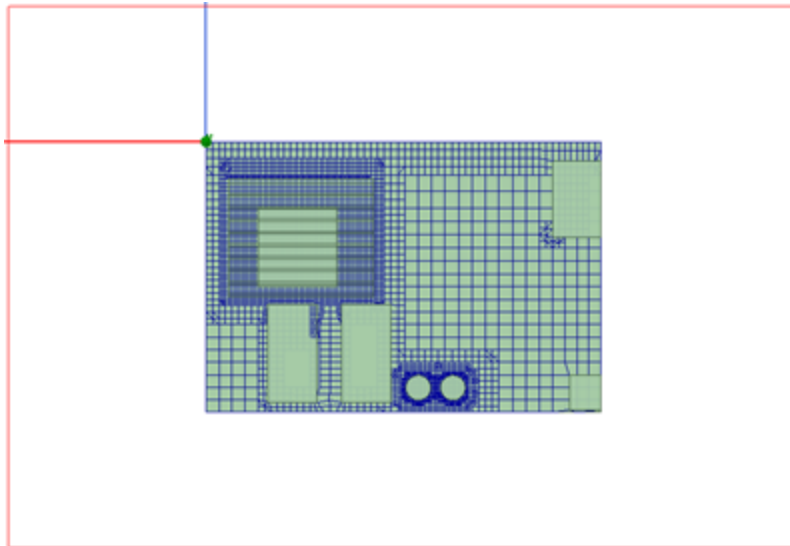

**Figure 4-5: Surface mesh on PCB object**

6. In the **Mesh visualization** dialog box, click the **Quality** tab and toggle between **Face alignment**, **Volume**, and **Skewness**, noting the **Min** and **Max** values for each.

**Note:** The following are targets value for face alignment and skewness that increase the probability of simulation convergence and accurate results.

- Face alignment: >0.05
  - Skewness: >0.02
7. Click **Close** to close the **Mesh visualization** dialog box.

## Validate the Project

It is a good practice to validate your project to ensure the model and all settings are within specified parameters in order to run a simulation.

1. From the **Icepak** menu, select **Validation Check**. The **Validation Check** dialog is displayed and the validations begins. When finished, green check marks appear next to the project items validated.

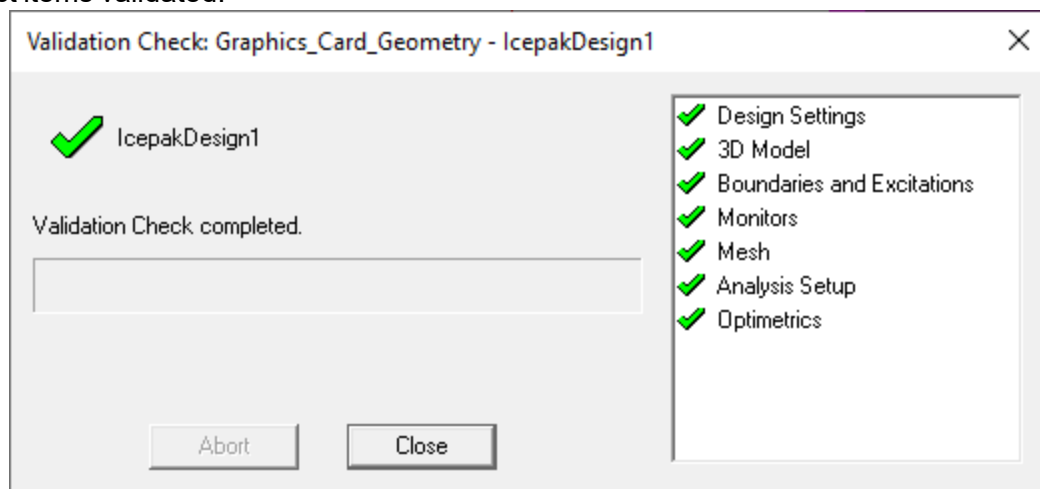

**Figure 4-6: Validation Check dialog box**

2. Click **Close** to close the **Validation Check** dialog box.

## Create Monitors

Monitor points are useful to display data at a specific point while the solver iterates. In this example, you'll create monitor points to display temperature data for the CPU and a memory chip.

## Create Thermal Monitors

### Create the CPU Monitor Point

1. In the history tree, right-click on the *CPU* object and select **Assign Monitor>Point**. The **Monitor Setup** dialog box appears.

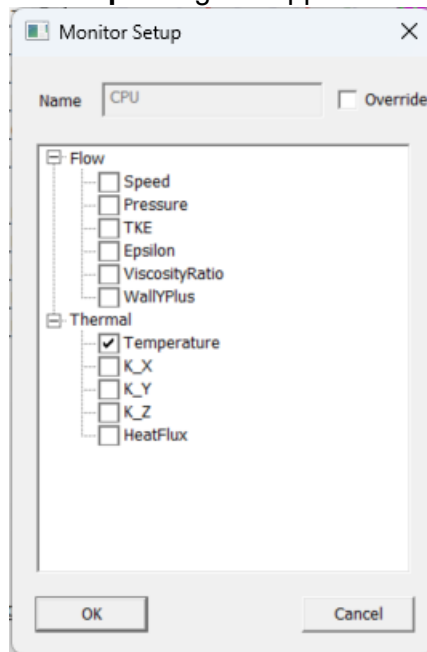



Figure 4-7: Monitor Setup dialog box - CPU

2. Enter a **Name** of CPU\_Monitor.
3. Under **Thermal**, select the **Temperature** check box.
4. Click **OK**. *CPU\_Monitor1* is created under **Monitor** in the **Project Manager**.

### Create the Memory Monitor Point

1. In the history tree, right-click on the *Memory1* object and select **Assign Monitor>Point**. The **Monitor Setup** dialog box appears.
2. Enter a **Name** of Memory\_Monitor.
3. Under **Thermal**, select the **Temperature** check box.
4. Click **OK**. *Memory\_Monitor1* is created under **Monitor** in the **Project Manager**.

## Create a Flow Monitor

1. From the **View** ribbon, select the Dimetric orientation option  from the **Orient** drop-down list.
2. Press F to ensure you are in face-selection mode.
3. Select the face of the *Region* object as displayed below.

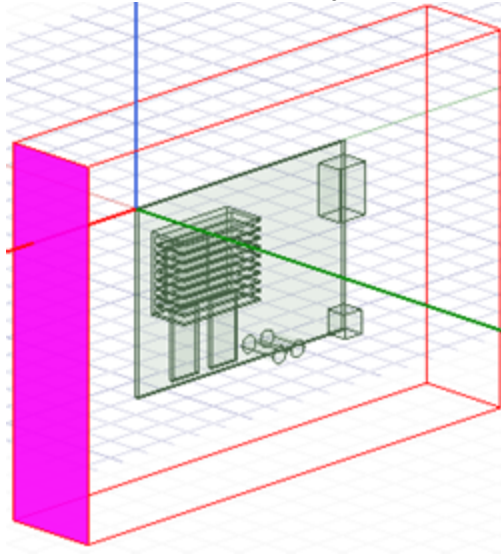

**Figure 4-8: Region face selection**

4. Right-click in the **3D Modeler** window, and select **Assign Monitor>Point**. The **Monitor Setup** dialog box appears.
5. Enter a **Name** of Exhaust\_Monitor.
6. Under **Flow**, select the **Speed** check box.
7. Click **OK**. *Exhaust\_Monitor1* is created under **Monitor** in the **Project Manager**.

## Analyze the Simulation – Initial Global Mesh

### Analyze the Model

1. In the **Project Manager**, right-click on the solution setup (*Setup1*) and select **Analyze** to run the simulation. The status of the simulation is displayed in the progress bar.
2. Right-click on the solution setup (*Setup1*) and select **Residual** to open the **Solutions** dialog box.
3. View the residuals update as the simulation runs.

**Note:** When the simulation is complete, a message is displayed in the **Message Manager** indicating normal completion.

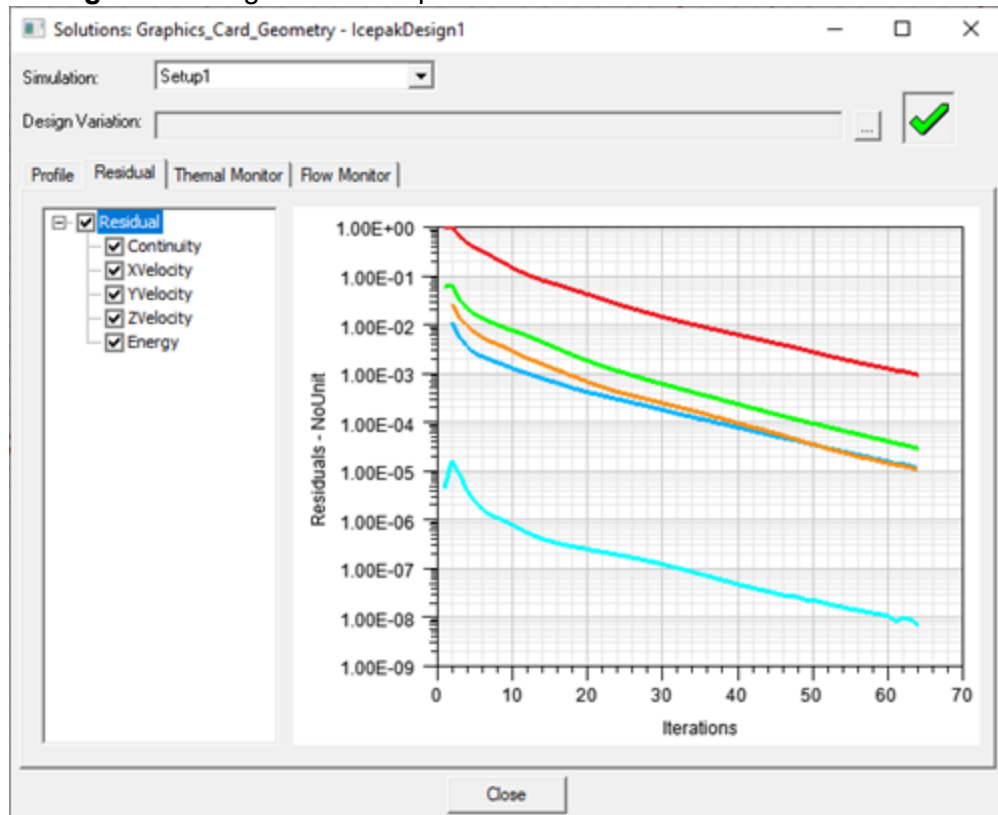

**Figure 4-9: Solutions dialog box - Residual tab**

4. Click the **Thermal Monitor** tab and review the monitor data.

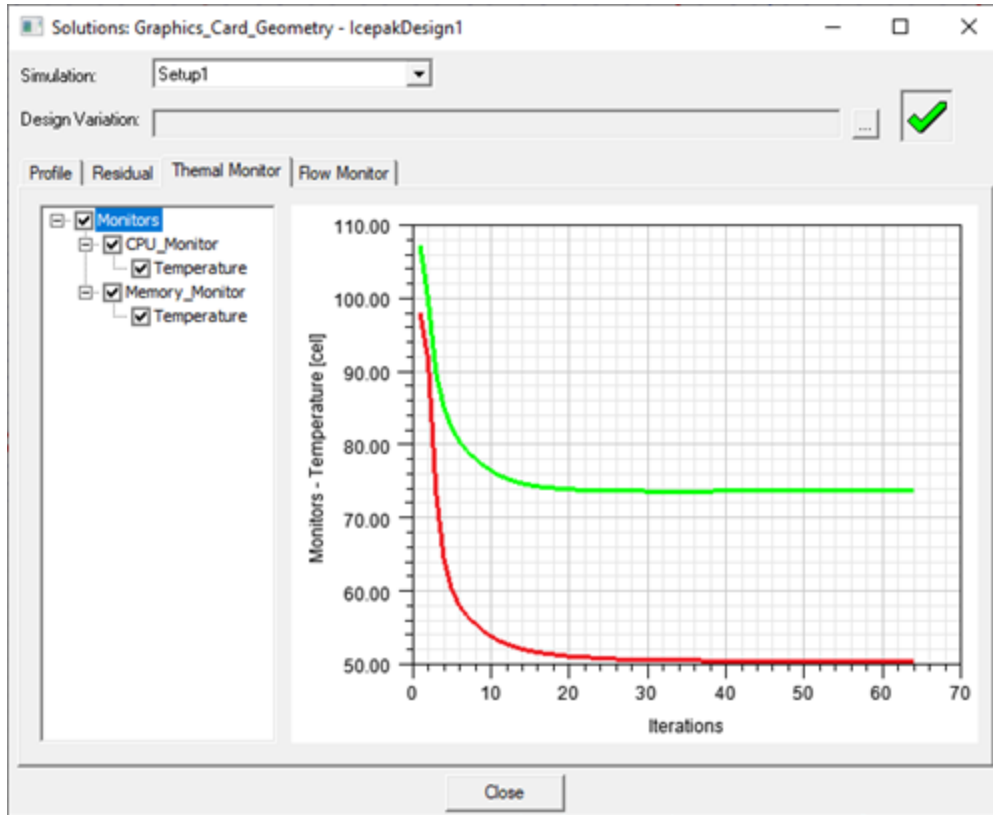

Figure 4-10: Solutions dialog box - Thermal Monitor tab

5. Click the **Flow Monitor** tab and review the monitor data.

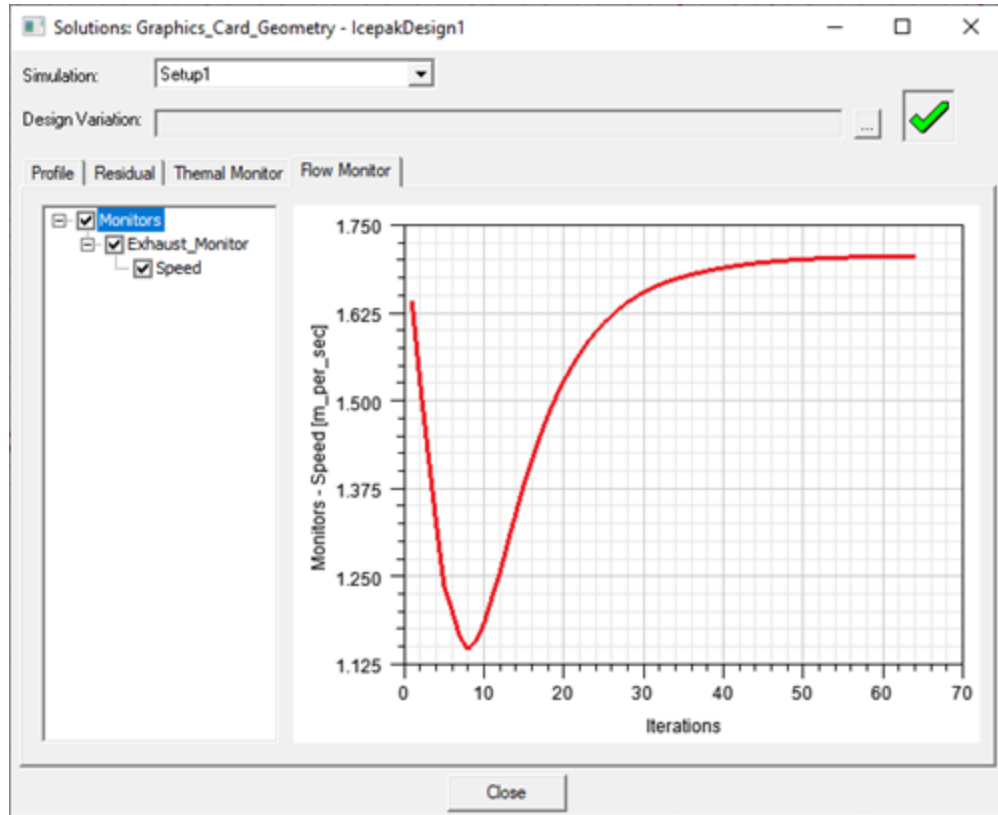

Figure 4-11: Solutions dialog box - Flow Monitor tab

## Post-process the Results – Initial Global Mesh

### Create Surface Plots

1. In the history tree, right-click *ALPHA\_MAIN\_PCB* and *HEAT\_SINK*, and select **Plot Fields>Temperature>Temperature**.
2. In the **Create Field Plot** dialog box, retain the default selection of **Temperature** under **Quantity**.
3. Select the **Plot on surface only** check box and click **Done**. Temperature contours are displayed on the PCB and heat sink objects, and the plot appears under **Field Overlays** in the **Project Manager**.
4. In the **3D Modeler**, right-click on the colorkey and select **Modify**. A dialog box is displayed.
5. Click the **Scale** tab and do the following under **Number Format**:
  - For **Type**, select **Decimal**.
  - For **Width**, enter 6.
6. Click **Save as default** and then **Close**.

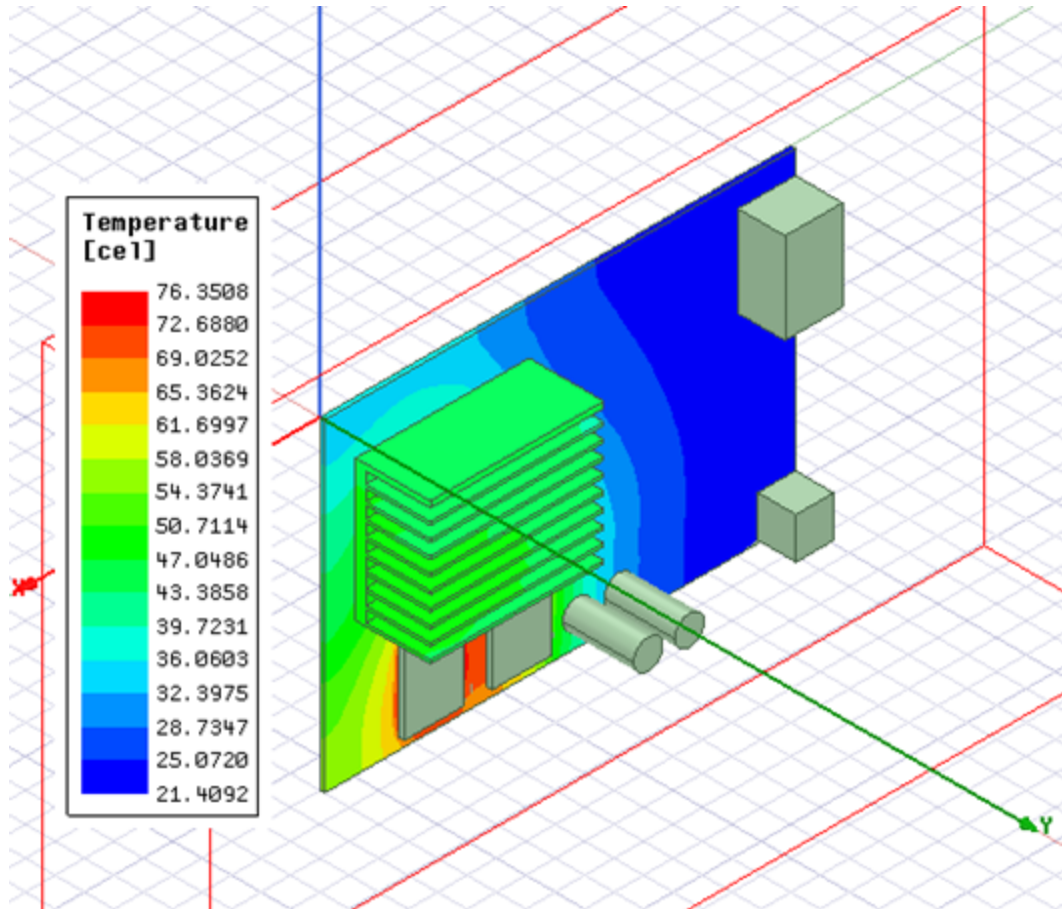

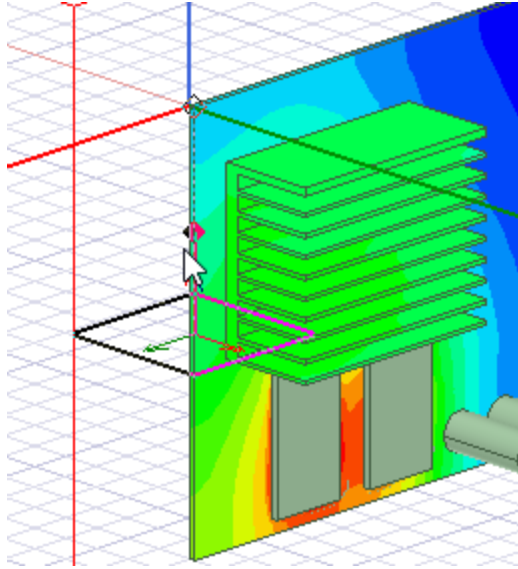

Figure 4-12: PCB and Heatsink temperature contours

## Create a Plane

In order to display temperature, pressure, and velocity on a plane cut, you must first create a plane. The plane will be in the middle of the PCB in the Z direction.

1. From the **View** ribbon, select click the Dimetric orientation button  from the **Orient** drop-down list.
2. From the **Draw** menu, select **Plane**.
3. In the **3D Modeler**, hover the cursor over the center of the edge of the PCB and click.



**Figure 4-13: Plane creation**

4. Hold **Z**, move the cursor up along the Z plane and click. The new plane displayed under **Planes** in the history tree.

## Create Plots on a Plane

1. In the history tree, select the plane you created.
2. In the **3D Modeler** window, right-click and select **Plot Fields>Pressure>Pressure**.
3. In the **Create Field Plot** dialog box, retain the default selection of **Pressure** under **Quantity** and click **Done**. Pressure contours are displayed on the plane.

**Note:** Click and drag the **Pressure** colorkey to also display the **Temperature** colorkey.

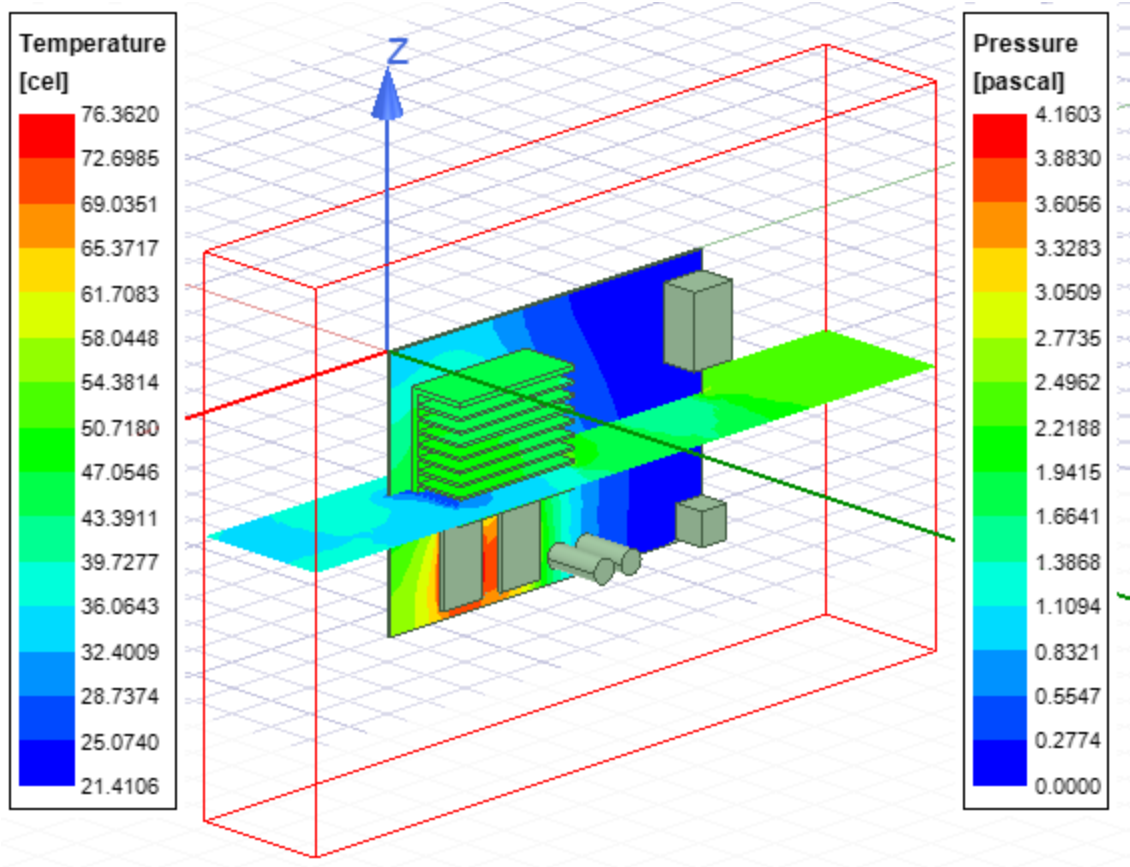

**Figure 4-14: Pressure contours on a plane**

4. In the **Project Manager** under **Field Overlays**, expand **Pressure**, right-click on the *Pressure1* plot and select **Modify Plot**.
5. In the **Modify Plot** dialog box, select **Temperature** under **Quantity** and click **Done** to display temperature contours on the plane.

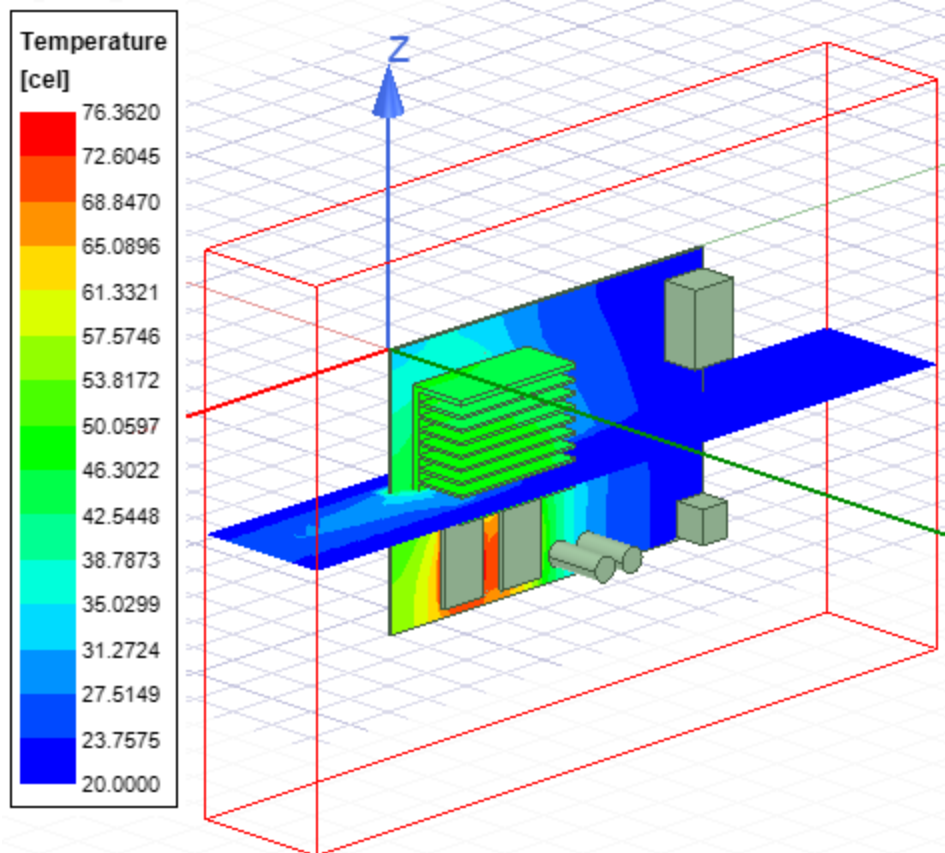

**Figure 4-15: Temperature contours on a plane**

- When you are finished observing the results, expand **Temperature** in the **Project Manager** and right-click on *Temperature1* and *Temperature2* and select **Plot Visibility** to hide the plots.

## Create a Fields Summary

- On the **Results** ribbon, click **Fields Summary**.
- In the **Setup Calculation** dialog under **Entity**, select **Grille1**.
- Under **Quantity**, select **Speed**.
- Click **Add** and select **Add as a Single Calculation**.
- In the **Setup Calculation** dialog box, select **Volume** for **Geometry Type**.
- Under **Entity**, select **CPU**.
- Under **Quantity**, select **Temperature**.
- Click **Add** and select **Add as a Single Calculation**.
- Under **Entity**, select **CPU** to clear the selection and then select **Memory**.
- Under **Quantity**, select **Temperature**.
- Click **Add** and select **Add as a Single Calculation**.

- Click **Close** to close the **Setup Calculation** dialog box. The calculations are displayed in the **Fields Summary** dialog box.

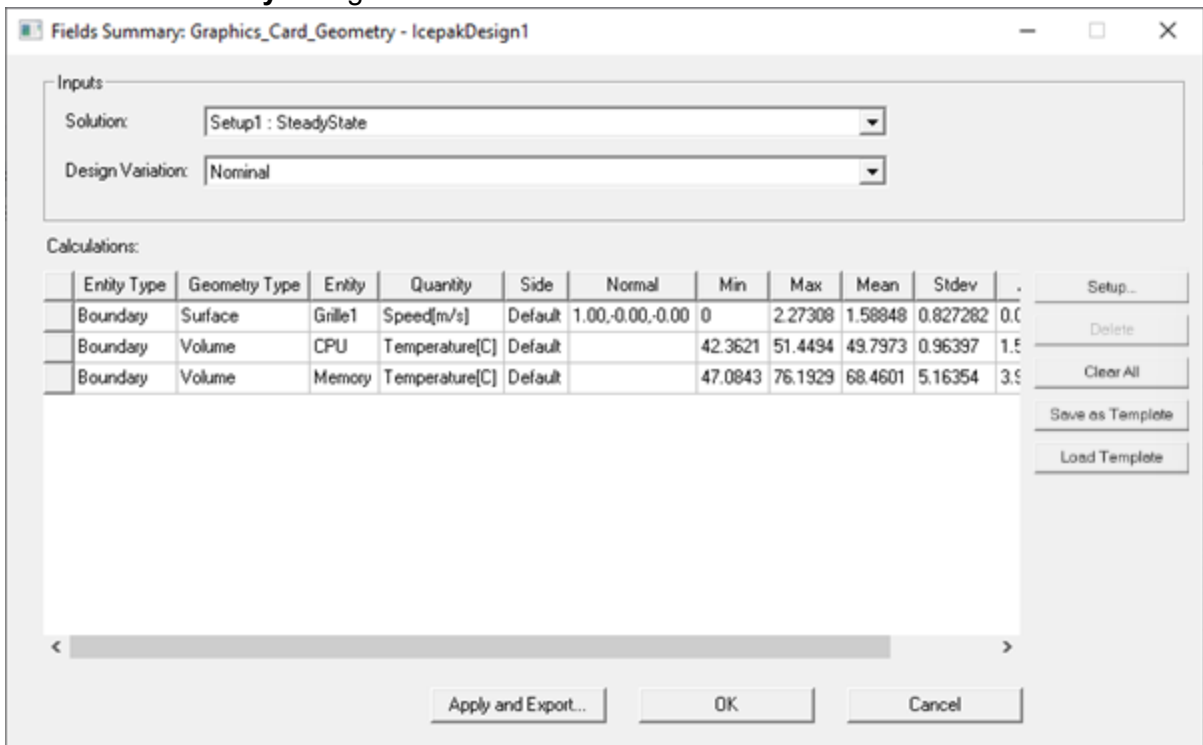

- Click **Apply and Export** to open the **Save As** dialog box. Navigate to your working directory and click **Save** to save the fields summary as a comma separated value spreadsheet.
- Click **OK** to close the **Fields Summary** dialog box.

## Create a Point

- From the **Draw** menu, select **Point**.
- Hover the cursor over the center of the grille.

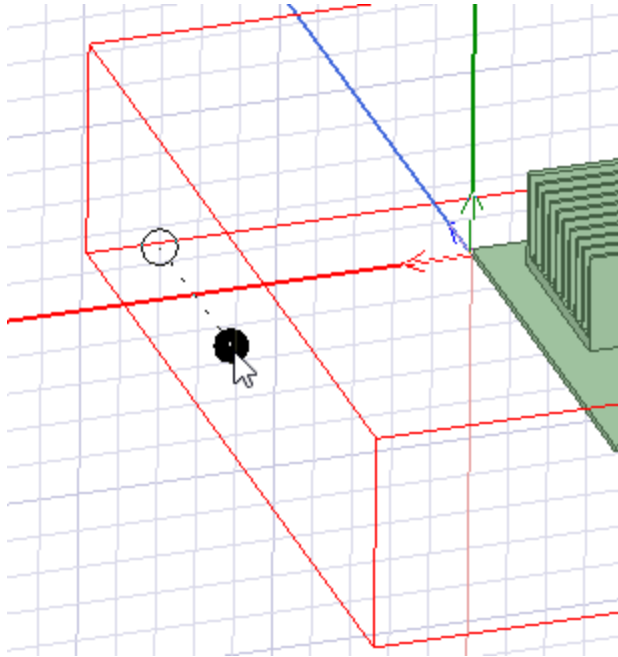

3. Click to create the point, which appears in the history tree as Point1.

## Use the Fields Calculator

1. In the **Project Manager**, right-click **Field Overlays** and select **Calculator**.
2. Under **Input**, click **Quantity** and select **Temp**.
3. Under **Input**, click **Geometry**.
4. In the **Geometry** dialog box, select **Volume** and **CPU**.
5. Click **OK**.
6. Under **Scalar**, click the **Min** and select **Value** from the drop-down list.
7. Under **Output**, click **Eval**. The result of the calculation is displayed in the stack area.
8. Repeats steps 2 through 7 for **Max** and **Mean** under **Scalar**.

**Note:** **Mean** does not require the selection of **Value**.

9. Click **Add**.
10. In the **Named Expression** dialog box, enter a name for the expression and click **OK**. The expression is saved to the **Named Expressions** list.
11. Under **Input**, click **Quantity** and select **U**.
12. In the **Geometry** dialog box, select **Point** and then **Point1**.
13. Under **Output**, click **Value** and then **Eval**. The result of the calculation is displayed in the

stack area.

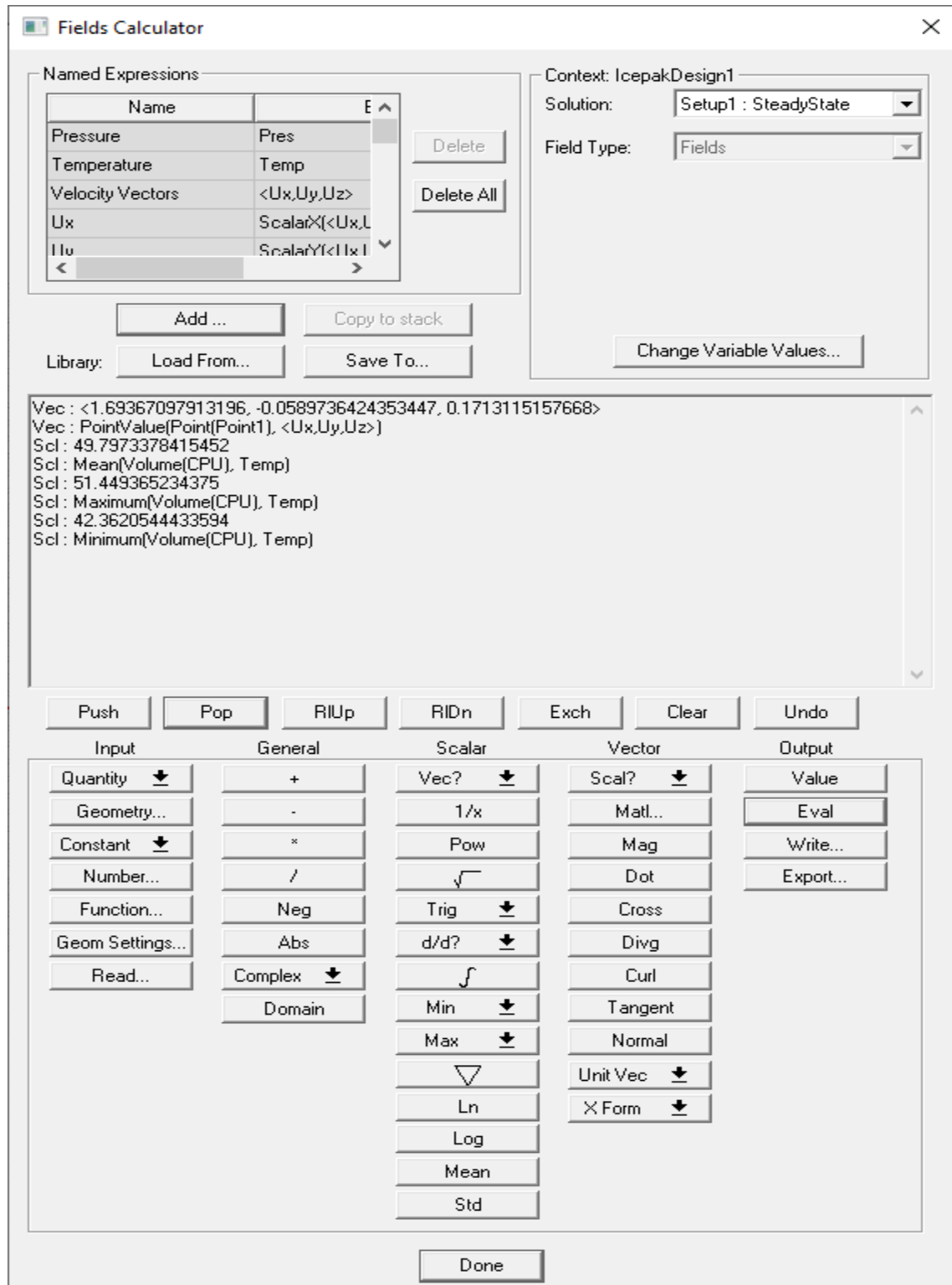

## Save the Project

From the **File** menu, click **Save**.



# 5 - Refine the Mesh and Run a Simulation

## Copy the Icepak Design

Create a copy of the Icepak design in order to compare the mesh and results of the original design to the copy with refined mesh.

1. In the **Project Manager**, right-click on the Icepak design and select **Copy**.
2. Right-click on the project and select **Paste**. A copy of the design is placed in the project folder.

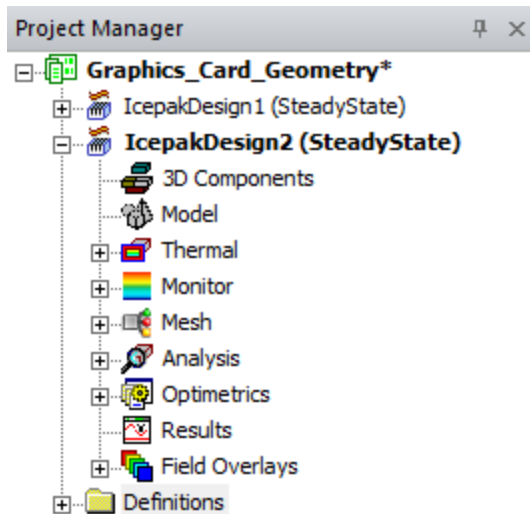

## Create a Mesh Region

Now you will create a mesh region around the heat sink to refine the mesh.

## Create the Mesh Region

1. Press **O** to enter object-selection mode.
2. In the **3D Modeler** window, select the heatsink.

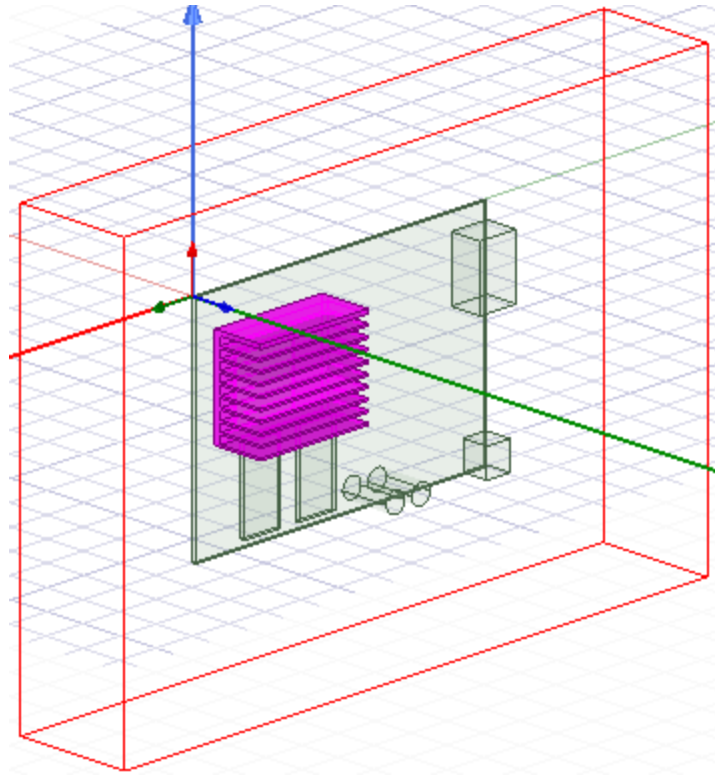

**Figure 5-1: Heatsink object selection**

3. Right-click and select **Assign Mesh Region**.
4. On the **SubRegion** dialog box, define padding settings as displayed in the following image

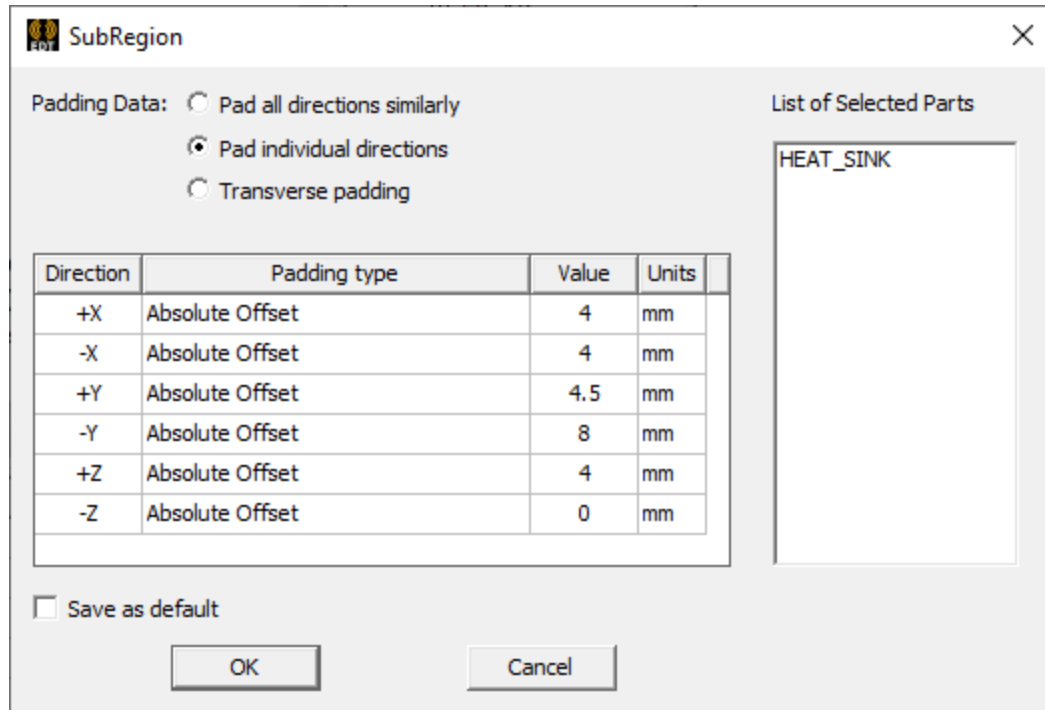

Figure 5-2: Properties window

5. Click **OK**.
6. In the **Mesh Region** dialog box, click **OK** to accept the default settings and create the mesh region. The mesh region appears under **Mesh** in the **Project Manager**, and its geometry is added to the history tree as a non-model box.

## Edit Mesh Region Settings

1. In the **Project Manager** under **Mesh**, double-click on *MeshRegion1*.
2. In the **Mesh** dialog box, enter a **Name** of *HeatSink*.
3. Move the **Resolution** slider to a finer resolution as displayed below and click **OK**.

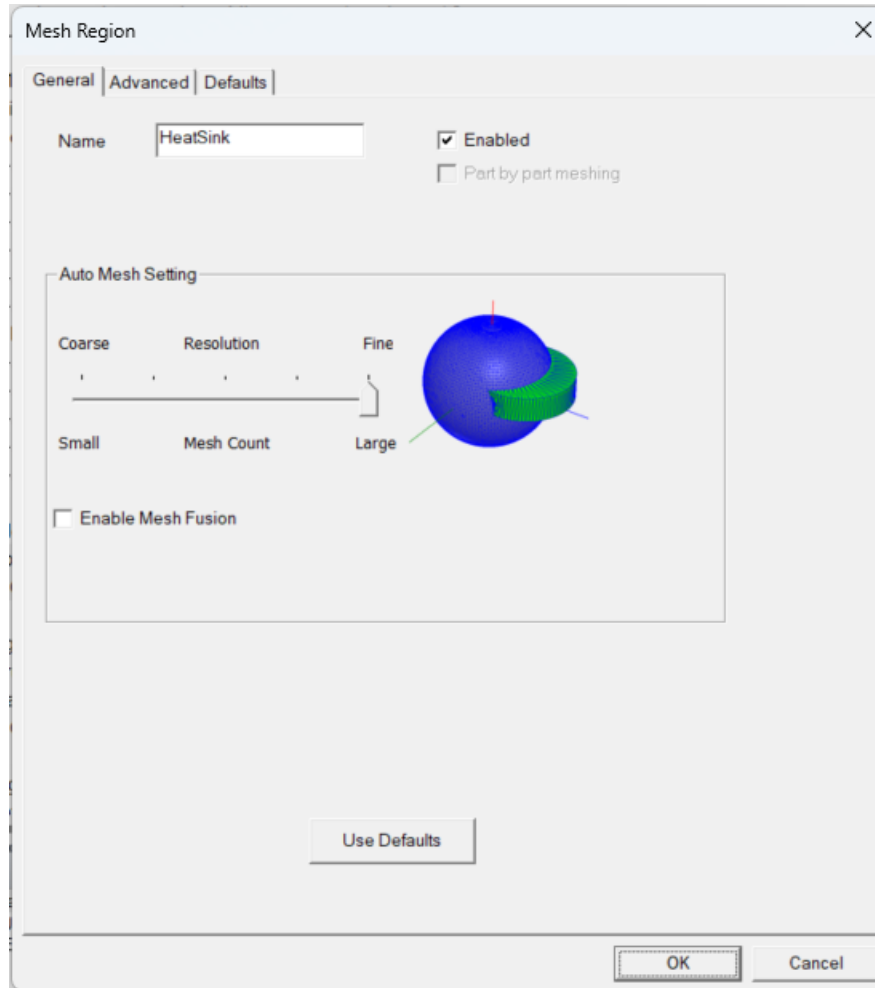

Figure 5-3: Mesh Regions dialog box

## Generate and Examine the Refined Mesh

Generate the mesh and examine the two levels of mesh, those reflecting the global mesh settings and those of the mesh region surrounding the heat sink.

1. In the **Project Manager** under **Analysis**, right-click on the solution setup and select **Generate Mesh**. When the mesh operation is complete, the mesh loads and the **Mesh visualization** dialog box appears.

**Note:** In the **Mesh visualization** dialog box under **Mesh display on**, ensure that **Show** is enabled.

2. In the history tree, select all geometry under *graphics\_card\_simple*.
3. Under **Mesh display on**, select **Show** and then **Geometry/Boundary selection** to display the mesh.

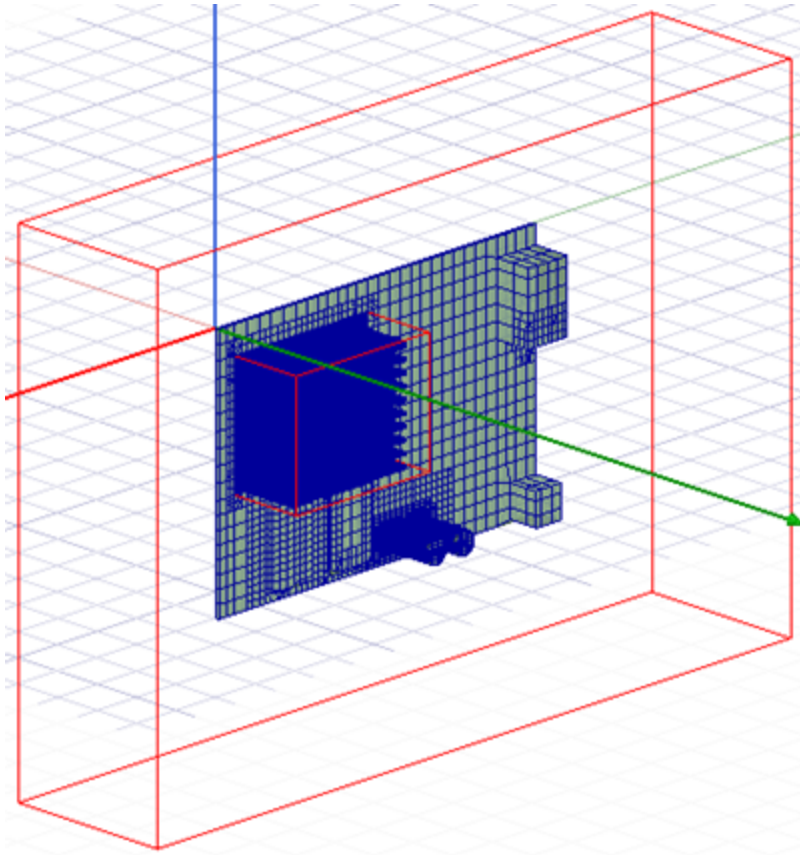

**Figure 5-4: Mesh on all objects**

4. In the history tree, select *ALPHA\_MAIN\_PCB* to display mesh only on the PCB.
5. On the **View** ribbon, click the **Right** orientation  option from the **Orient** drop-down list.

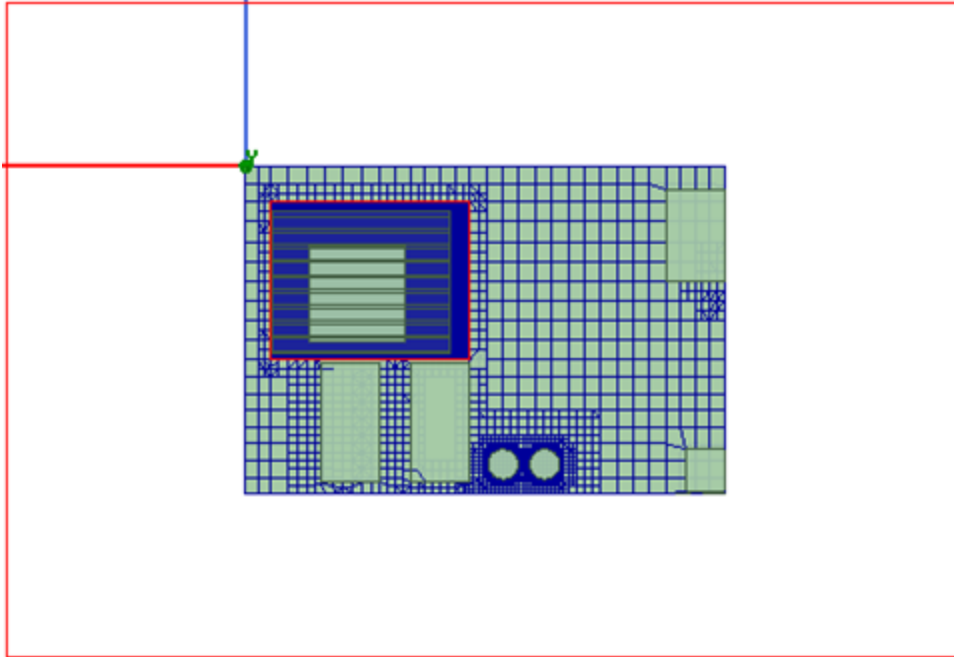

**Figure 5-5: Surface mesh on PCB object**

**Note:** Notice the finer resolution within the mesh region surrounding the heat sink.

6. Click **Close** to close the **Mesh visualization** dialog box.

## Analyze the Simulation – Refined Mesh

### Analyze the Model

1. In the **Project Manager**, right-click on the solution setup and select **Analyze** to run the simulation. The status of the simulation is displayed in the progress bar.
2. Right-click on the solution setup and select **Residual** to open the **Solutions** dialog box.
3. View the residuals update as the simulation runs.

**Note:** When the simulation is complete, a message is displayed in the **Message Manager** indicating normal completion.

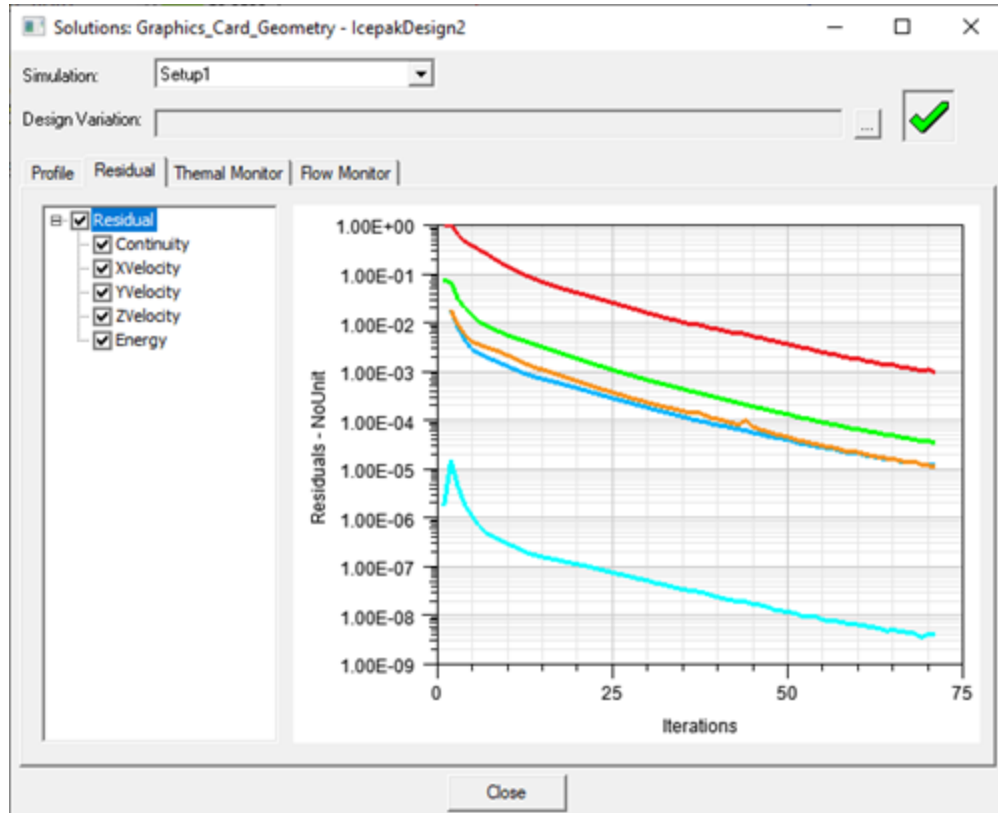

Figure 5-6: Solutions dialog box - Residual tab

4. Click the **Thermal Monitor** tab and review the monitor data.

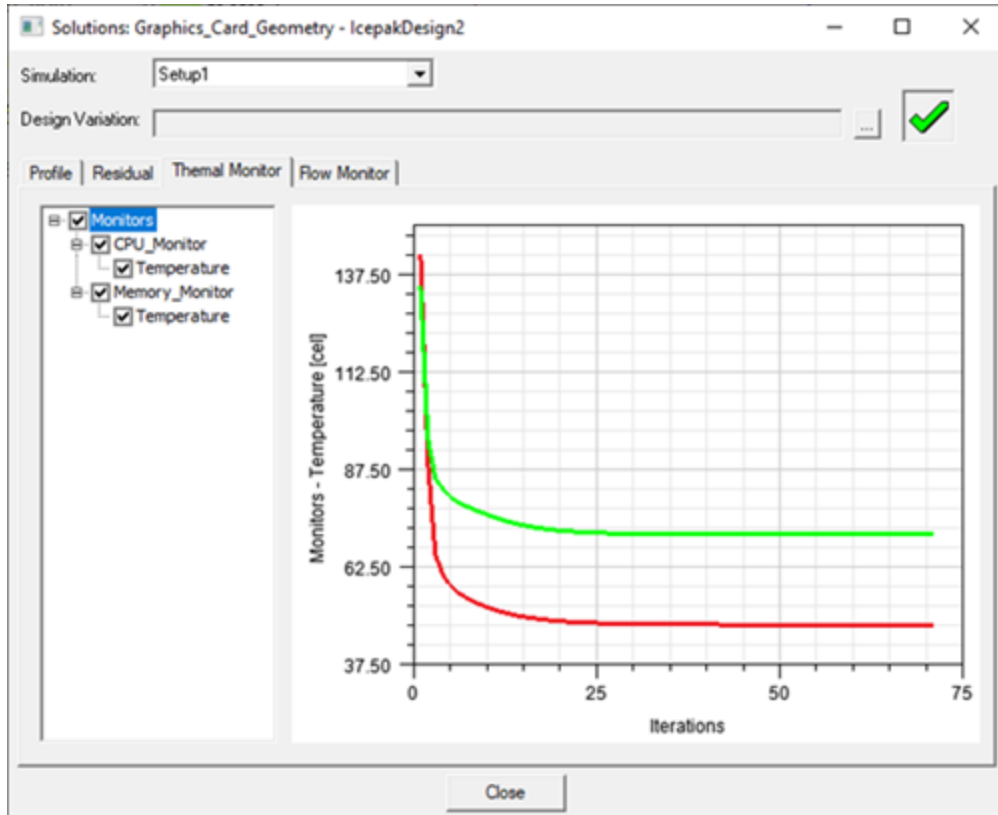

Figure 5-7: Solutions dialog box - Thermal Monitor tab

5. Click the **Flow Monitor** tab and review the monitor data.

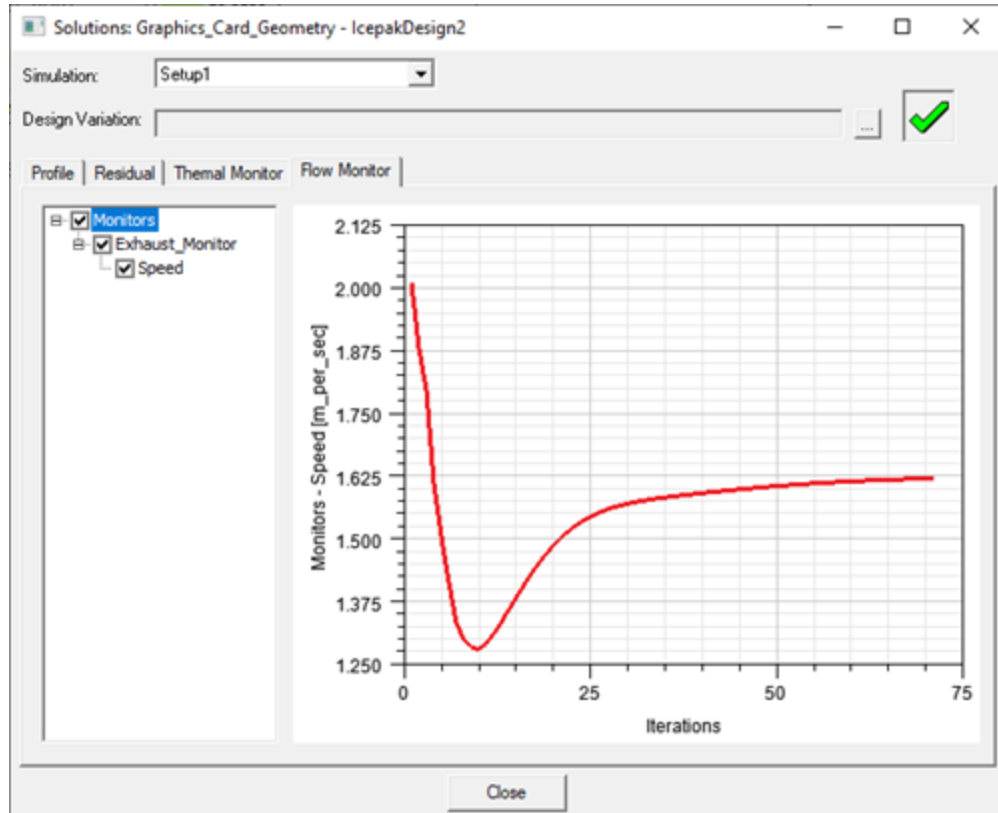

Figure 5-8: Solutions dialog box - Flow Monitor tab

## Post-process the Results – Refined Mesh

1. In the **Project Manager** under **Field Overlays**, select *Temperature2*, right-click, and select **Plot Visibility**.
2. Select *Temperature2*, right-click, and select **Modify Plot**.
3. In the **Modify Plot** dialog box under **Quantity**, select **Velocity Vectors**.

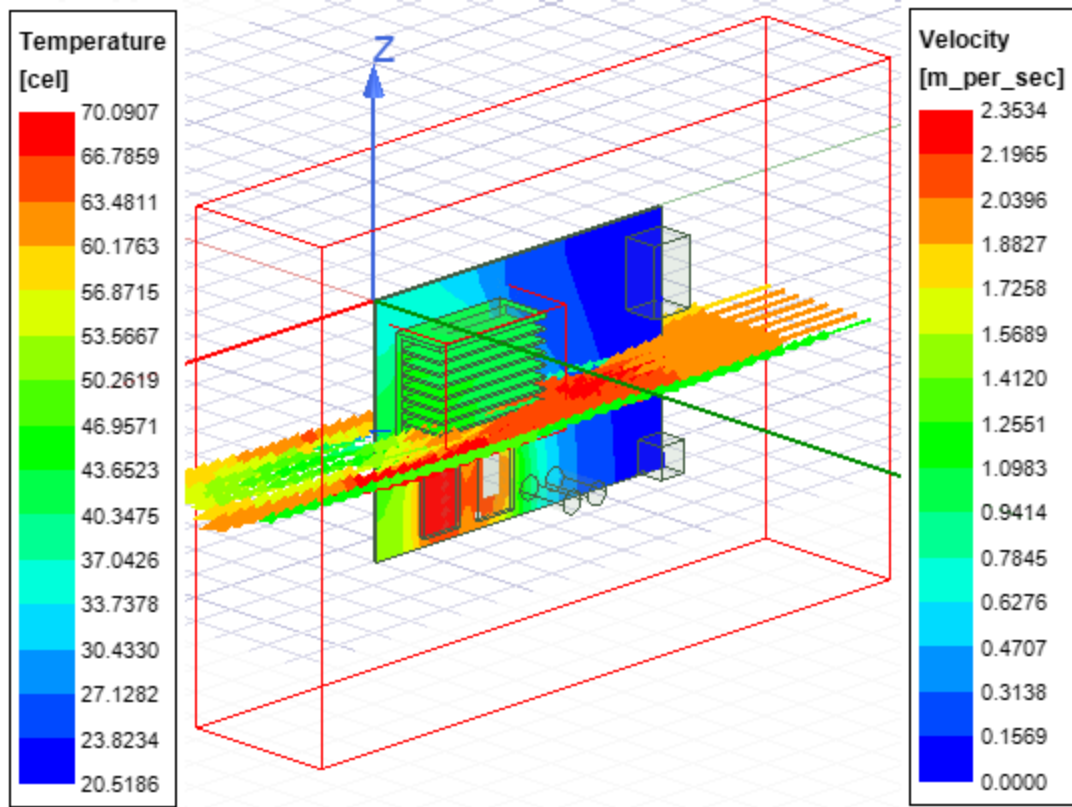
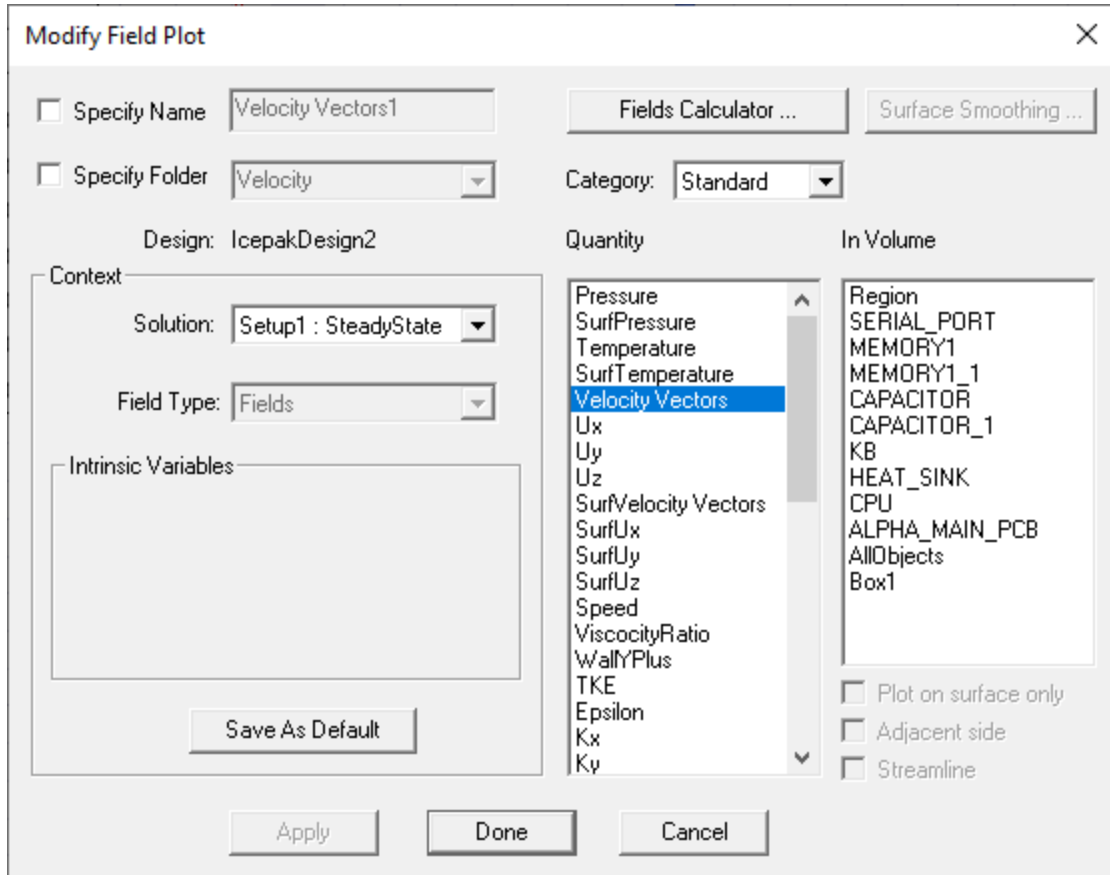

Figure 5-9: Temperature and velocity plots

4. Click **Done**. The temperature and velocity plots are displayed in the **3D Modeler** window.

**Note:** Click and drag the **Velocity** colorkey to also display the **Temperature** colorkey.



**Figure 5-10: Temperature and velocity plots**

- When you are finished reviewing the results, expand **Temperature** in the **Project Manager** and right-click on *Temperature1* and *Velocity Vectors1* and select **Plot Visibility** to hide the plots.

## Compare the Designs

Creating a copy of the original Icepak design within the same Ansys Electronics Desktop project and using it to refine the mesh allows you to compare the mesh and simulation results. In the **Project Manager**, switch between the original Icepak design and the copied design with the refined mesh region to compare the meshing and simulation results.

## Save the Project

From the **File** menu, click **Save**.



## 6 - Run Optimetric Trials

### Note:

To run Icepak optimetrics, the Enterprise Electronics license or Optimetrics equivalent license is required.

## Create and Assign Project Variables

You will use the copy of the Icepak design with the refined mesh (*IcepakDesign2*) to run the optimetric trials. Before setting up the optimetrics, create and assign the project variables.

### Create Project Variables

1. From the **Project** menu, select **Project Variables** to open the **Properties** dialog box.
2. On the **Project Variables** tab, select **Optimization/Design of Experiments**.
3. Click **Add** to open the **Add Property** dialog box. Define the settings as follows and then click **OK**.
  - **Name:** \$CPU\_Power
  - **Unit Type:** Power
  - **Unit:** W
  - **Value:** 25

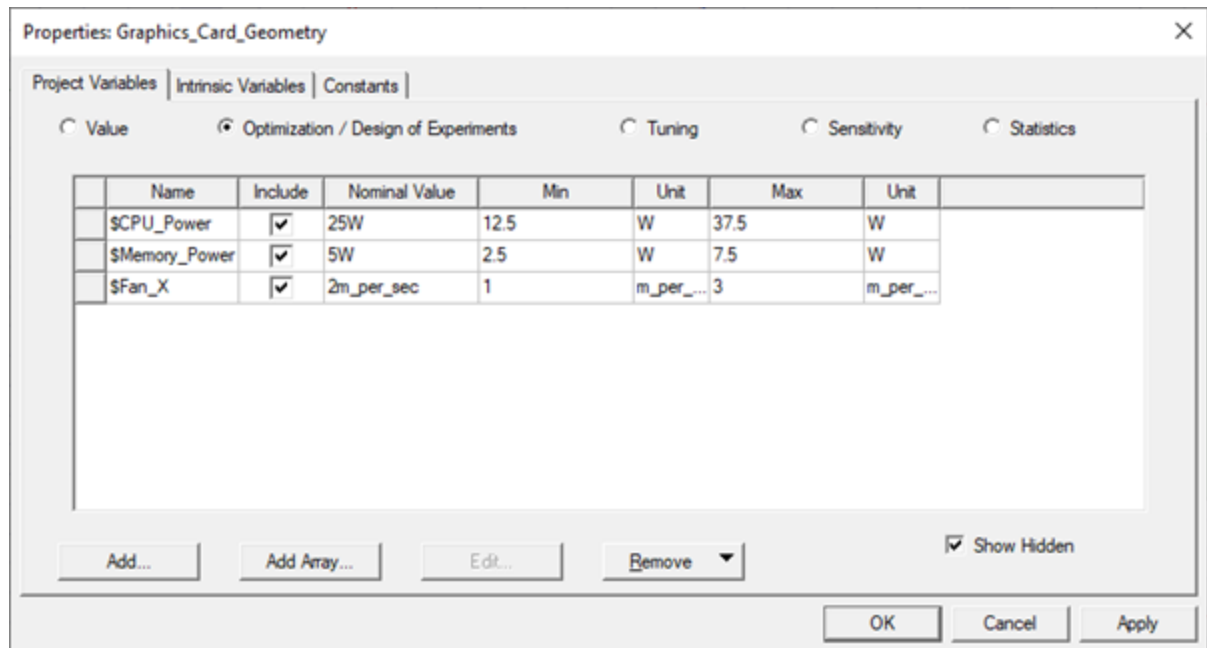

Figure 6-1: Add Property dialog box

4. Click **Add** again to open the **Add Property** dialog box. Define the settings as follows and then click **OK**.
  - **Name:** \$Memory\_Power
  - **Unit Type:** Power

- **Unit:** W
  - **Value:** 5
5. Click **Add** again to open the **Add Property** dialog box. Define the settings as follows and then click **OK**.
    - **Name:** \$Fan\_X
    - **Unit Type:** Speed
    - **Unit:** m\_per\_sec
    - **Value:** 2

The **Properties** dialog box now displays the three variables with nominal, minimum, and maximum values.



**Figure 6-2: Properties dialog box with variables**

6. Select the **Include** check box for each variable.
7. Click **OK** to close the **Properties** dialog box.

## Assign Project Variables

1. In the **Project Manager** under **Thermal**, double-click the **CPU** boundary condition to open the **Block Thermal Model** dialog box.
2. In the **Total Power** field, enter \$CPU\_Power and click **OK**.

**Note:** Variable names are case-sensitive. You must enter the name exactly as it was defined.

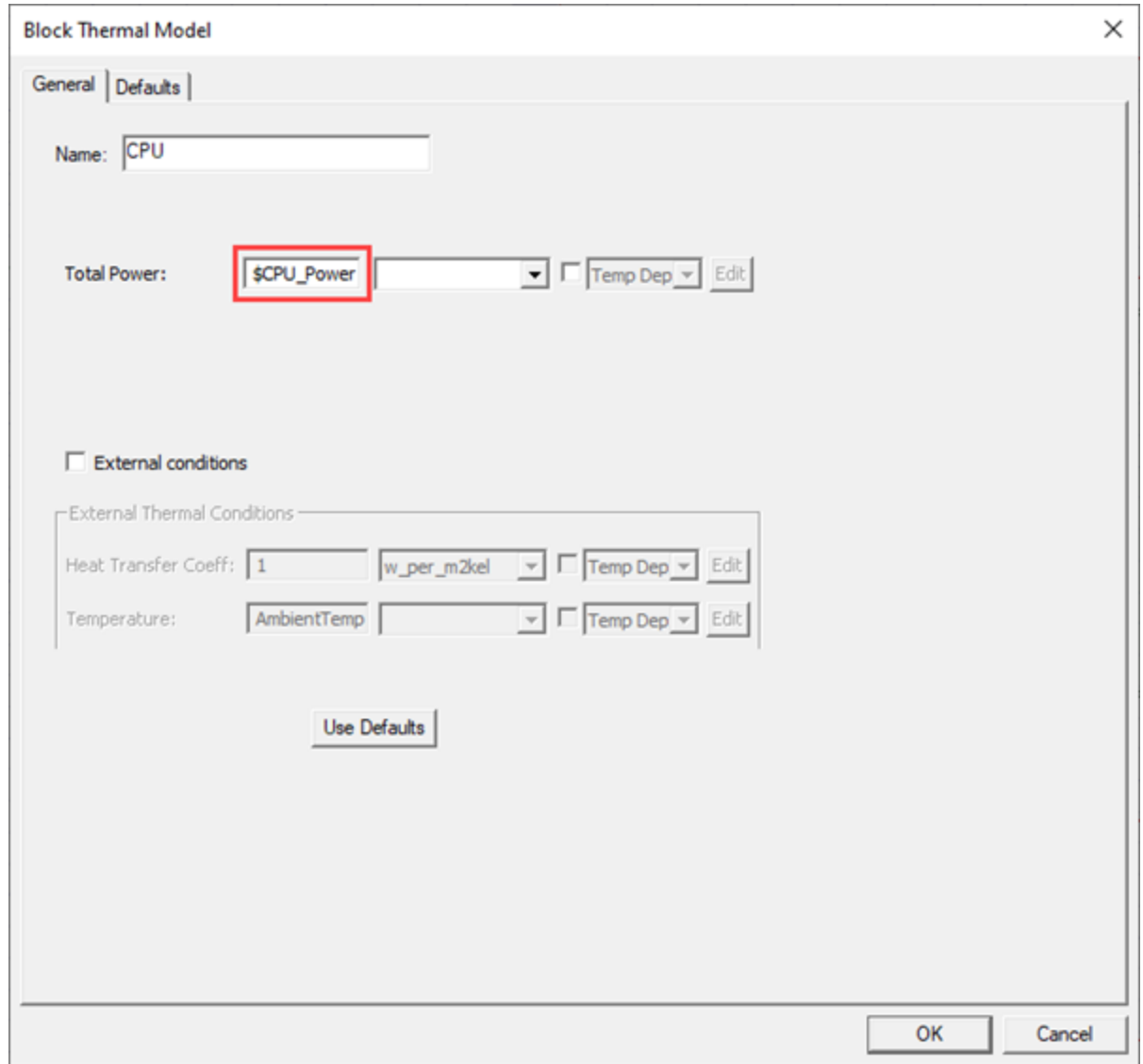

**Figure 6-3: Block Thermal Model dialog box with variable**

3. In the **Project Manager** under **Thermal**, double-click the **Memory** boundary condition to open the **Block Thermal Model** dialog box.
4. In the **Total Power** field, enter `$Memory_Power` and click **OK**. The **Unit** field is left blank.

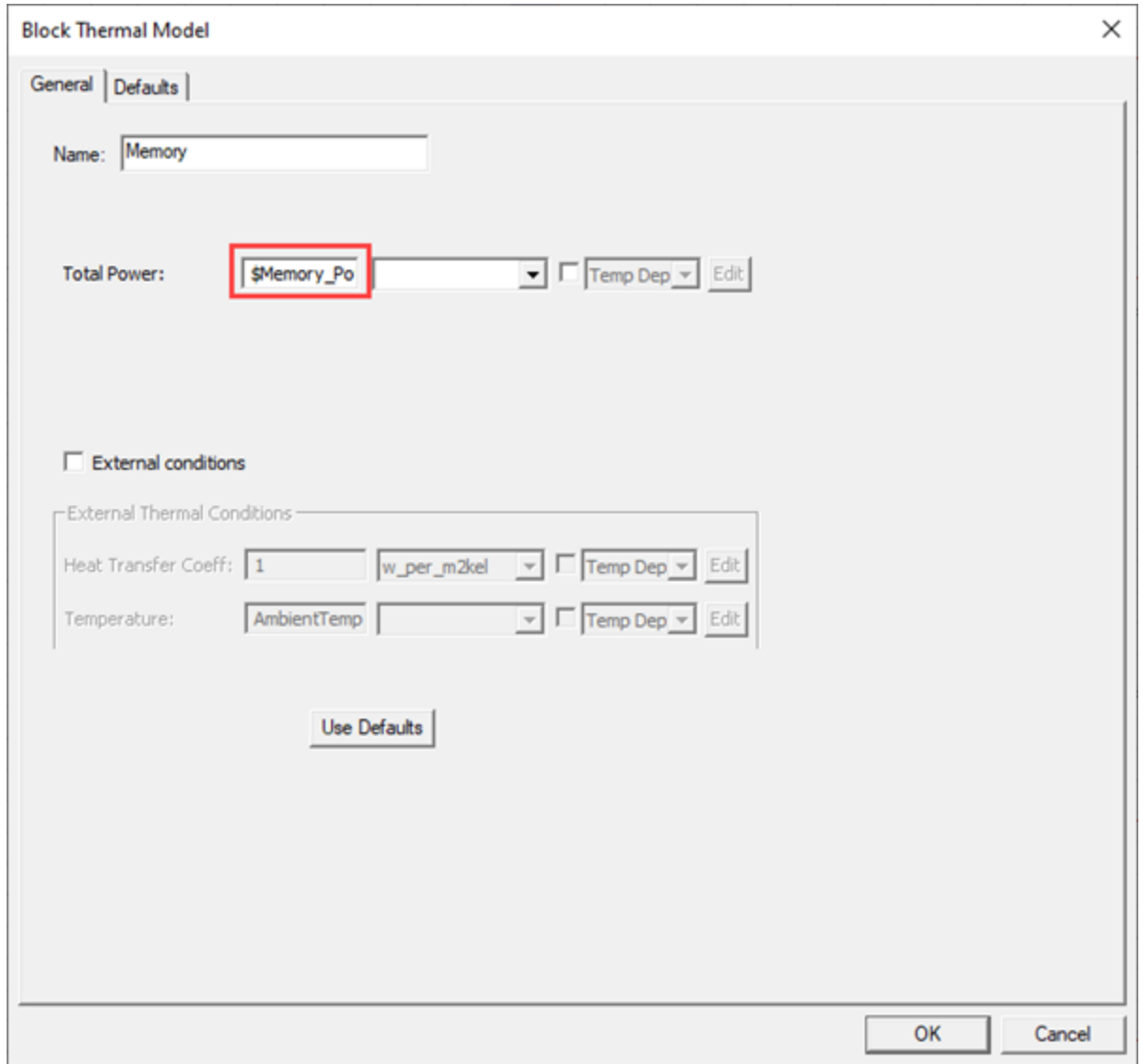

**Figure 6-4: Block Thermal Model dialog box with variable**

5. In the **Project Manager** under **Thermal**, select the **Opening1** boundary condition.
6. In the **Properties** window, enter \$Fan\_X in the **X Velocity Value** field. The **Unit** field is left blank.

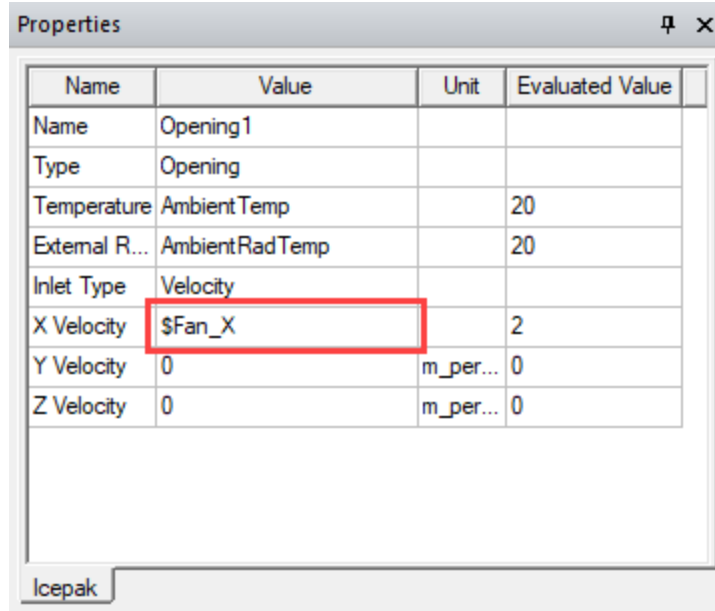

Name	Value	Unit	Evaluated Value
Name	Opening1		
Type	Opening		
Temperature	AmbientTemp		20
External R...	AmbientRadTemp		20
Inlet Type	Velocity		
X Velocity	\$Fan_X		2
Y Velocity	0	m_per...	0
Z Velocity	0	m_per...	0

Figure 6-5: Opening1 properties with variable

## Add a Design of Experiments Setup

1. From the **Icepak>Optimetrics Analysis** menu, select **Add Design of Experiments**. to open the **Design of Experiments** dialog box.
2. On the **Design of Experiments** tab, select **Central Composite Design** from the **Design of Experiments Type** drop-down list.

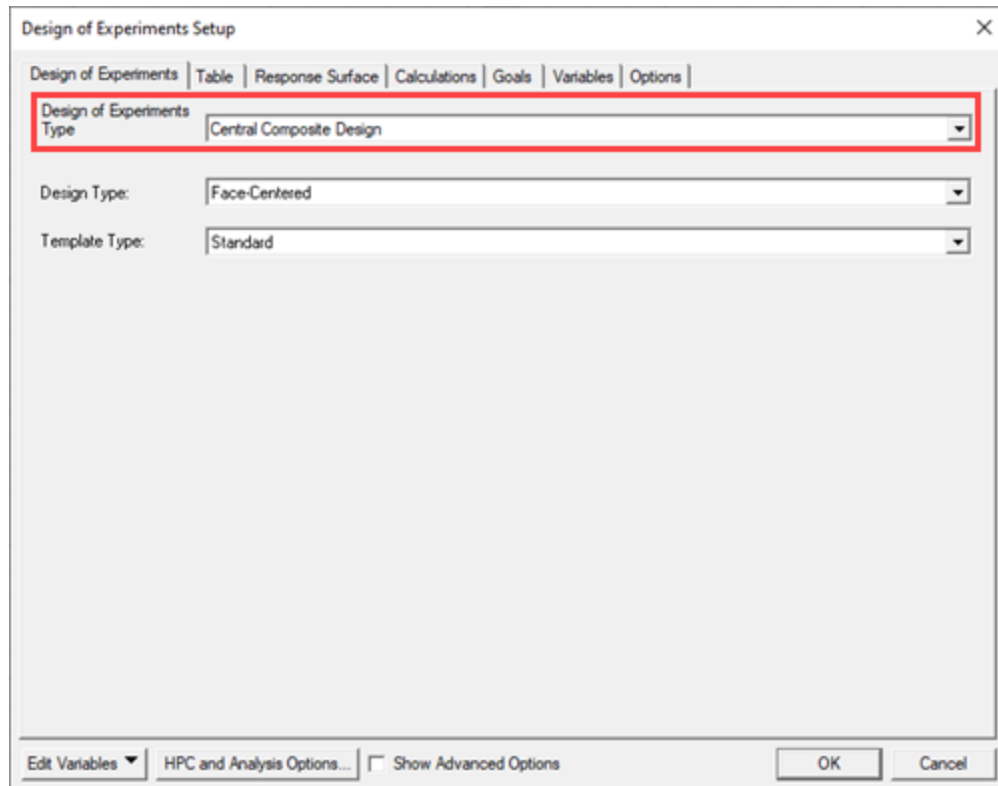

**Figure 6-6: Design of Experiments Setup dialog box - Design of Experiments tab**

3. Click the **Table** tab, and review the trials to be run.

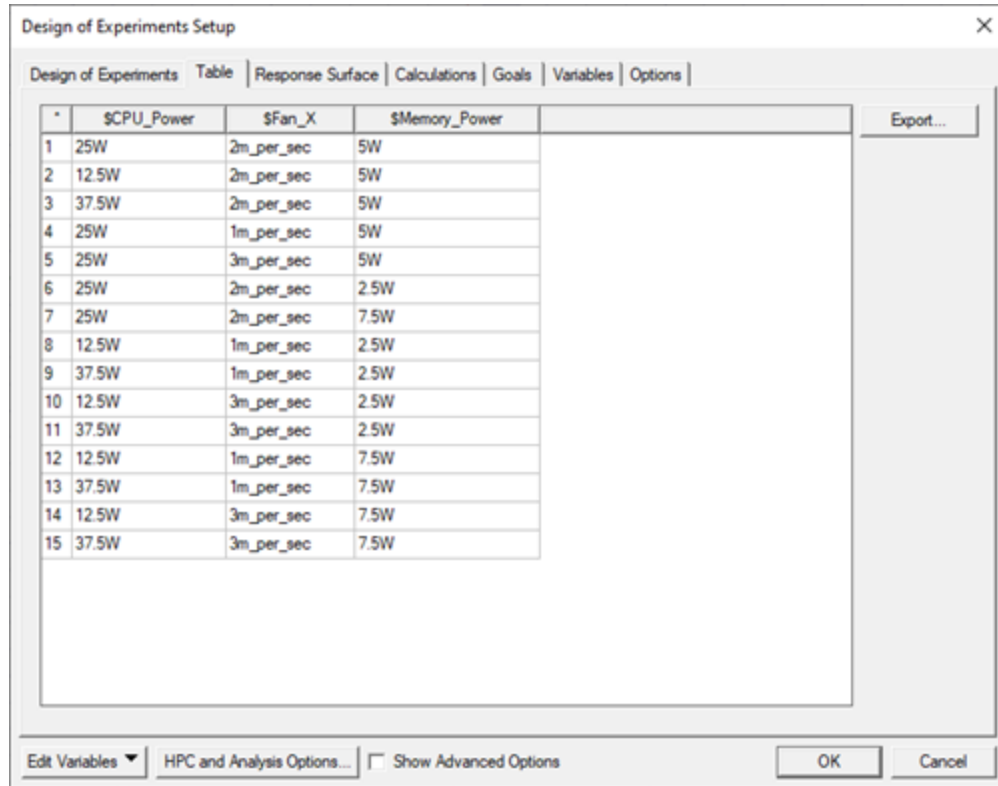
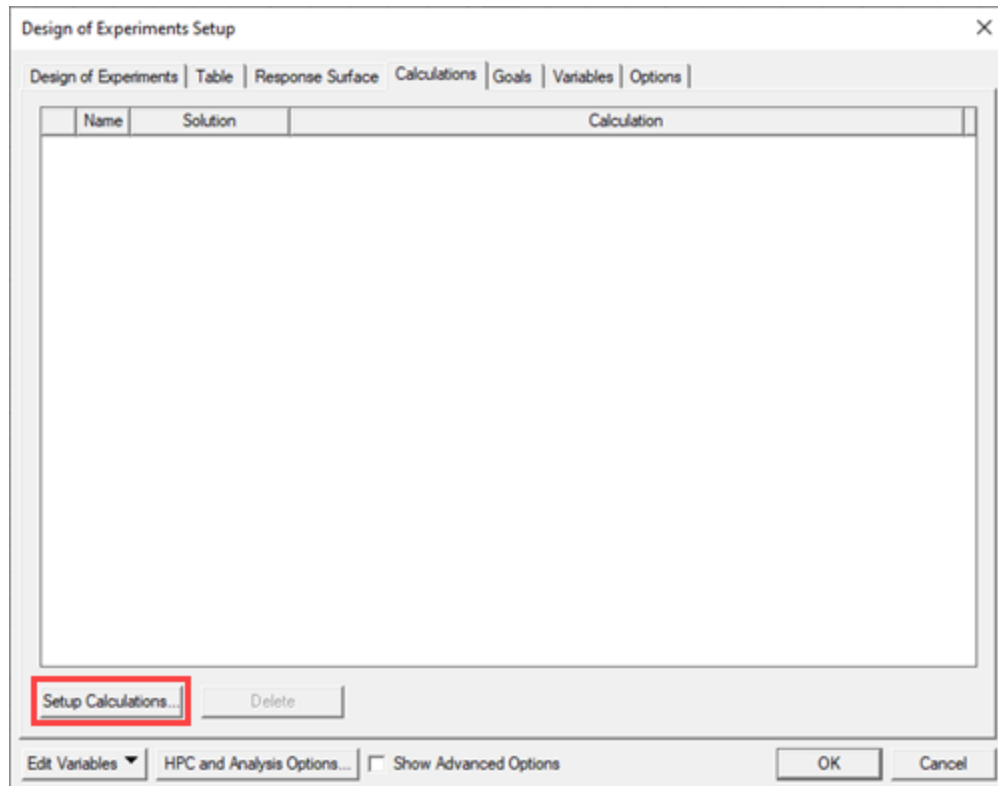

Figure 6-7: Design of Experiments Setup dialog box - Table tab

4. Click the **Calculations** tab.
5. Click **Setup Calculations**.



**Figure 6-8: Design of Experiments Setup dialog box - Calculations tab**

6. In the **Add/Edit Calculation** dialog box, select **Monitor** under **Category** and **CPU\_Monitor.Temperature** under **Quantity**.
7. Click **Add Calculation**.

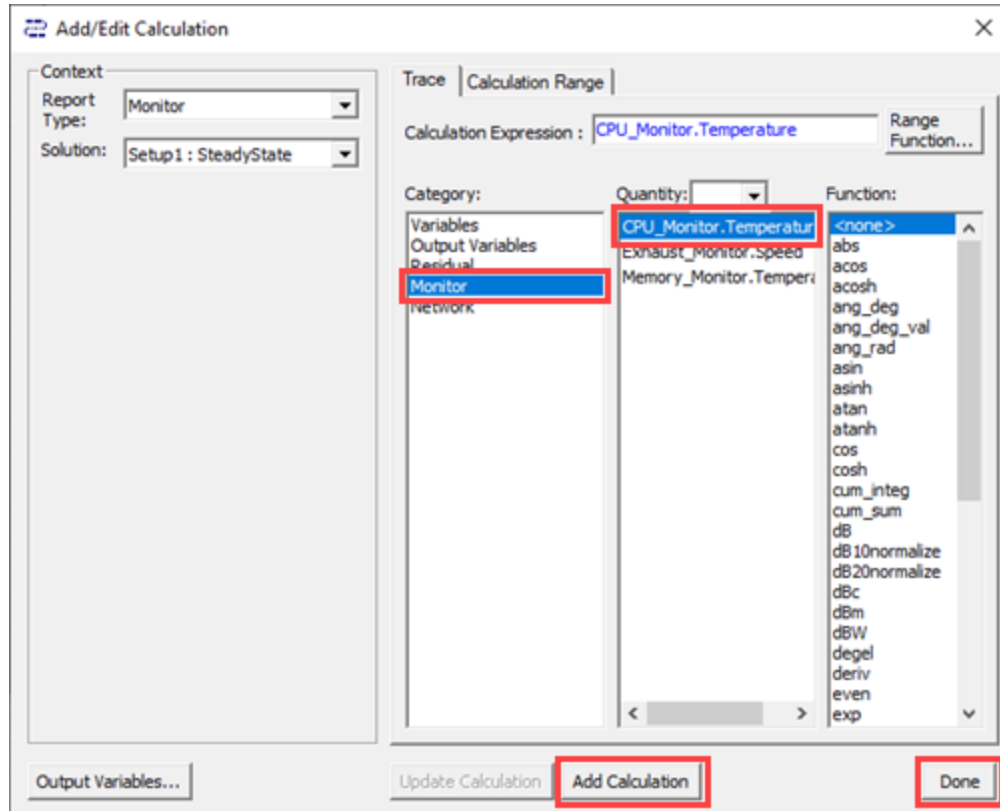
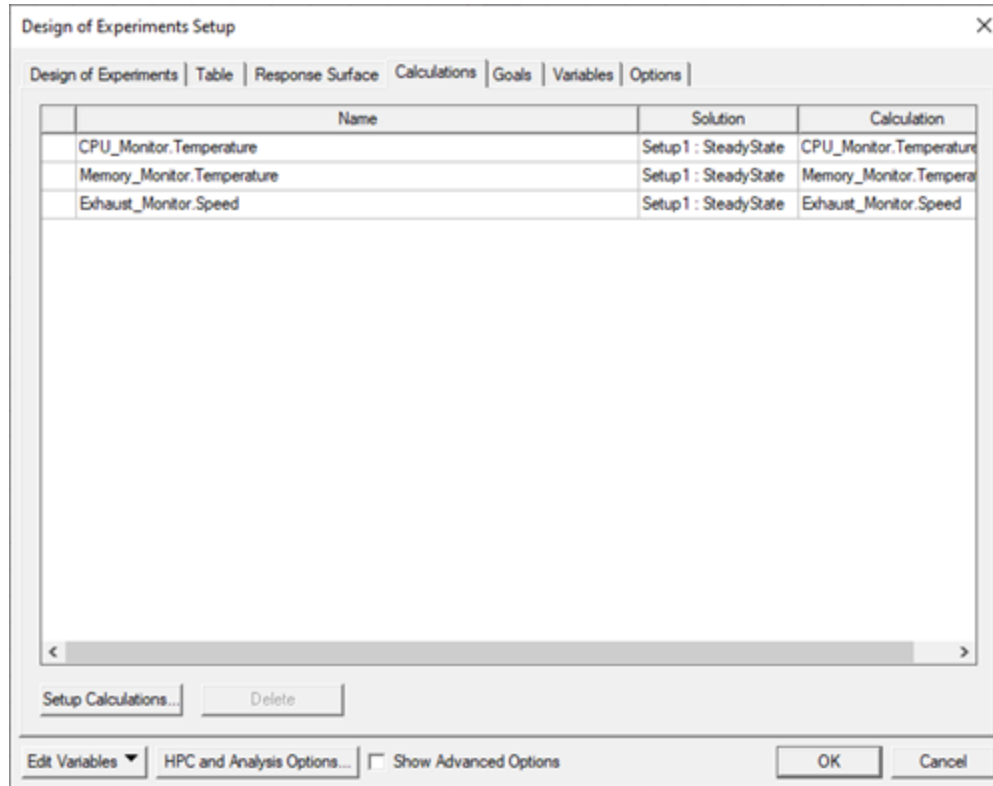

Figure 6-9: Add/Edit Calculation dialog box

8. Select **Memory\_Monitor.Temperature** under **Quantity**.
9. Click **Add Calculation**.
10. Select **Exhaust\_Monitor.Speed** under **Quantity** and click **Add Calculation**.
11. Click **Done** to close the **Add/Edit Calculation** dialog box.



**Figure 6-10: Design of Experiments Setup dialog box - populated Calculations tab**

12. Click **OK** to close the **Design of Experiment Setup** dialog box.

## Analyze the Design of Experiments

1. In the **Project Manager**, expand **Optimetrics** and right-click **DesignOfExperimentsSetup1**.
2. From the right-click menu, select **Analyze**.

**Note:** Depending on the hardware and licensing configuration, the trials can take upwards of 15 minutes to complete.

3. After the analysis is complete, right-click **DesignOfExperimentsSetup1** and select **View Analysis Result** to open the **Post Analysis Display** dialog box.
  - On the **Result** tab, toggle between the **Table** and **Plot** views to display data for each variation.

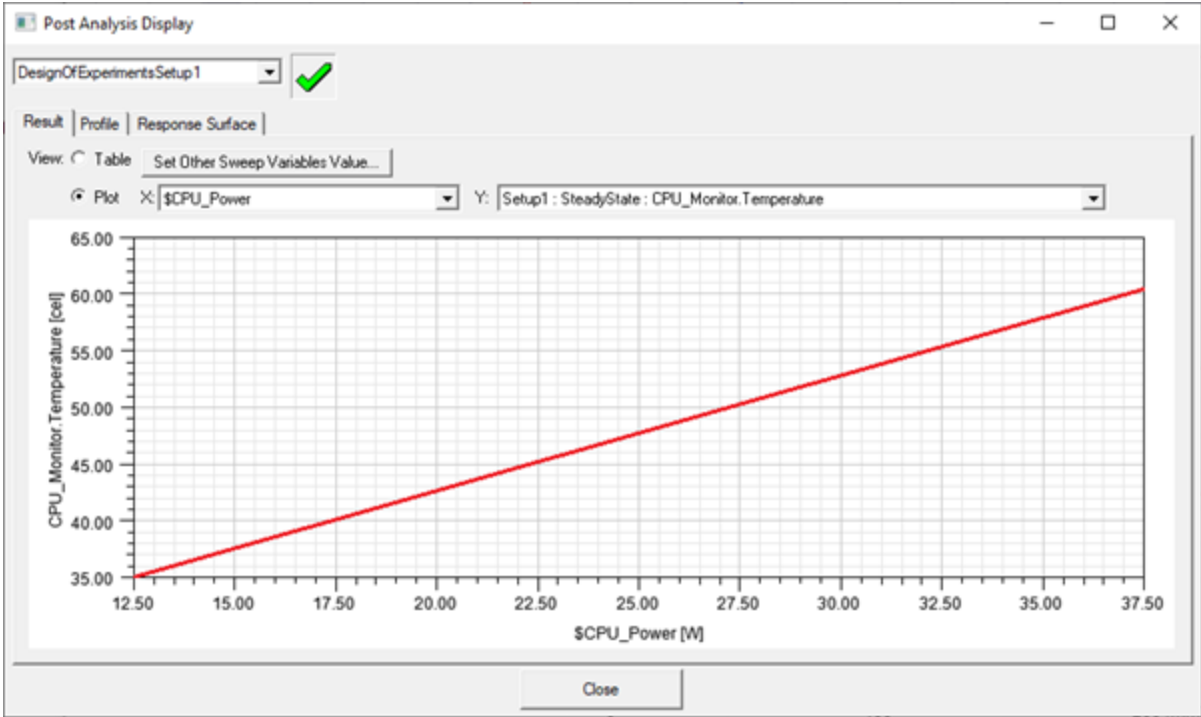

Figure 6-11: Post Analysis Display - Result tab Plot

- Next to **View**, select **Table** to review the table displaying data for each variation.

The screenshot shows the 'Post Analysis Display' window with the 'Table' view selected. The table displays 14 variations of simulation results. The columns include Variation, \$CPU\_Power, \$Fan\_X, \$Memory\_Power, CPU\_Monitor.Temperat..., Memory\_Monitor.Temp..., and Exhaust\_Monitor Speed. The table is scrollable, and buttons for 'Export...', 'Apply', and 'Revert' are visible on the right side.

Variation	\$CPU_Power	\$Fan_X	\$Memory_Power	CPU_Monitor.Temperat...	Memory_Monitor.Temp...	Exhaust_Monitor Speed
1	25W	2m_per_sec	5W	47.749667cel	70.896532cel	1.6203873m_per_sec
2	12.5W	2m_per_sec	5W	35.062921cel	67.612268cel	1.6203834m_per_sec
3	37.5W	2m_per_sec	5W	60.434351cel	74.178522cel	1.6207696m_per_sec
4	25W	1m_per_sec	5W	63.059747cel	84.512781cel	0.79655498m_per_sec
5	25W	3m_per_sec	5W	42.576624cel	64.470972cel	2.4597018m_per_sec
6	25W	2m_per_sec	2.5W	46.560266cel	48.730493cel	1.6207658m_per_sec
7	25W	2m_per_sec	7.5W	47.797418cel	89.514276cel	1.7609308m_per_sec
8	12.5W	1m_per_sec	2.5W	41.529901cel	52.256464cel	0.79655415m_per_sec
9	37.5W	1m_per_sec	2.5W	79.988519cel	64.552637cel	0.79656357m_per_sec
10	12.5W	3m_per_sec	2.5W	31.288141cel	42.235498cel	2.4599242m_per_sec
11	37.5W	3m_per_sec	2.5W	52.213892cel	46.918207cel	2.459878m_per_sec
12	12.5W	1m_per_sec	7.5W	46.131311cel	104.47314cel	0.79655749m_per_sec
13	37.5W	1m_per_sec	7.5W	84.589929cel	116.76913cel	0.79655361m_per_sec
14	12.5W	2m_per_sec	7.5W	22.929478cel	92.022727cel	2.4599144m_per_sec

Figure 6-12: Post Analysis Display - Result tab Table

- On the **Response Surface** tab, view the data for each variation based on the selection in the **View** drop-down list.
  - Next to the **View** drop-down list, click the ... button to open the **Response Curves (2D Slices)** dialog box.

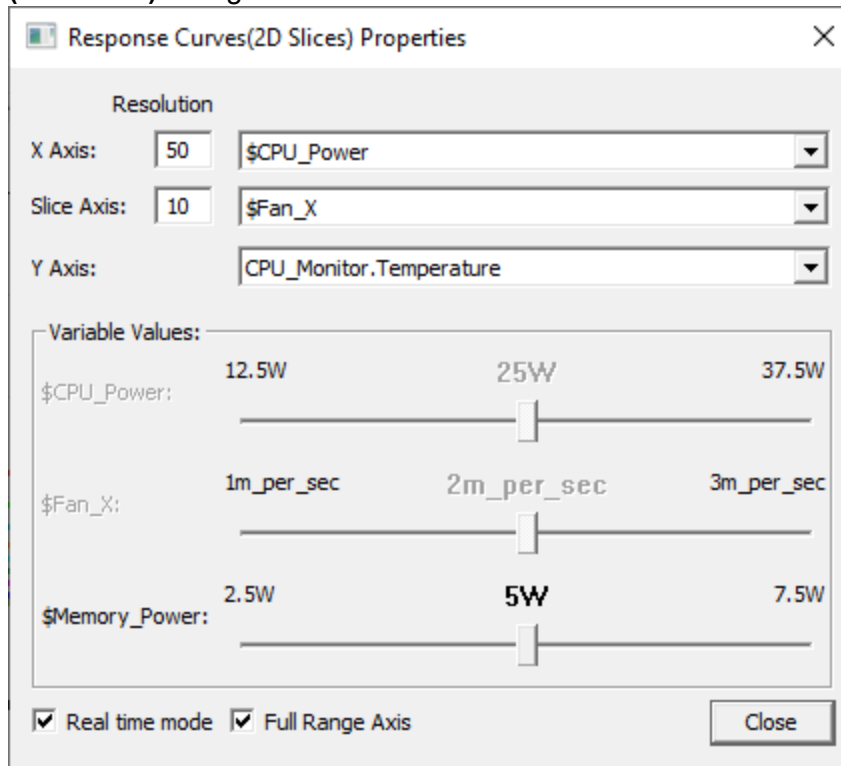

**Figure 6-13: Response Curves (2D Slices) Properties**

- In the **Slice Axis** field, enter **10**.
- Select various configurations for the axes, and use the slider bar to change the power of the CPU and memory and the speed of the fan. With the **Real time mode** check box selected, the response surface is updated automatically. Click **Close**.

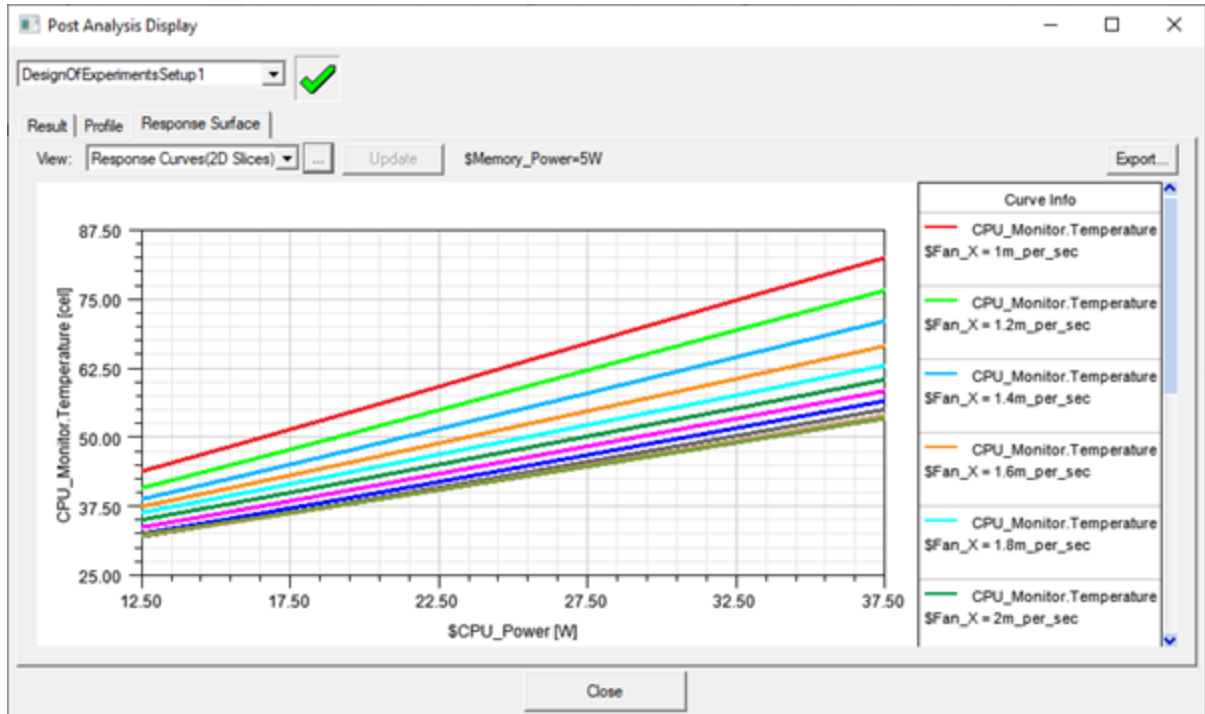

**Figure 6-14: Post Analysis Display - Response Curves (2D Slices)**

- From the **View** drop-down list, select **Response Surface** to display a 3D response surface.
- Click the ... button to open the **Response Surface** dialog box.
- Select various configurations for the axes, and use the slider bar to change the power of the CPU and memory and the speed of the fan. With the **Real time mode** check box selected, the response surface is updated automatically.

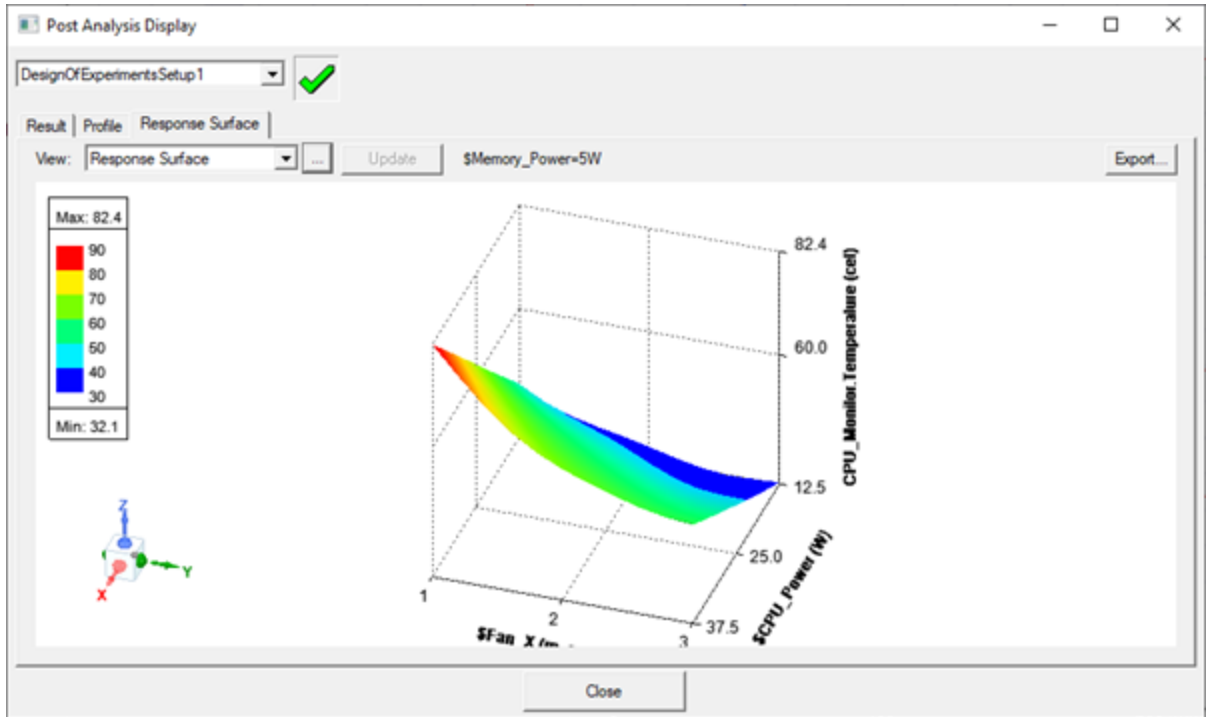

Figure 6-15: Post Analysis Display - Response Surface